

SPECIFICATIONS

MODEL SB-102

SSB TRANSCEIVER



The Heathkit SB-102 . . . proud descendent of the rigs that put many thousands of hams on the air . . . the famous "100" and "101". With a heritage like this you expect greater value, top performance, unequalled versatility and high reliability — and you get it.

Solid-State Linear Master Oscillator . . . the heart of the SB-102. Heath leadership in producing rigs that are rock-stable and highly accurate is well known, and the "102" is no exception. The new solid-state LMO delivers frequency stability, linearity and resettability characteristics seconds to none . . . compare these specs against any rig at any price. And the "102" also warms up in half the time of most other transceivers. For easier, more accurate tuning, the new solid-state LMO features 1 kHz dial calibration and bandspread equal to 10 feet per Megahertz . . . sorting out those closely-packed stations is a breeze with the "102". And to assure exceptional accuracy and make kit assembly faster, the LMO is factory assembled and precisely aligned.

Hotter Receiver Circuitry . . . lets you pull in stations that just aren't there on other rigs. Sensitivity is better than 0.35 μ V for 10 dB (S+N)/N ratio . . . gives you solid copy longer when the band is on the way out.

Power Input Consistent With Maximum Versatility. The SB-102 delivers 180 watts SSB PEP input . . . more than sufficient to let you get out with a good, healthy signal. This power level permits using the right tubes for the job — rugged, dependable, low cost 6146's specifically designed for RF work — and does not require eliminating useful features to pay for increased power. The "102" is ideally suited for driving a grounded grid linear, such as the Heathkit SB-200 or SB-220, for a really big signal without the problems of excessive drive.

Exclusive Heath TALC (Triple Action Level Control™) compresses the speech waveform without flat-topping. This ALC voltage is derived from three separate points to assure maximum transmitter output without overloading . . . peak positive grid current on the finals is rectified and fed to the ALC circuit . . . variations in the final screen supply

produce additional ALC voltage . . . ALC voltage from an external linear amplifier can also be fed to the SB-102 through the built-in jack on the rear panel. The clean, undistorted signals of the Heath SB-Series are often used as a standard of comparison . . . and TALC is one of the big reasons.

Maximum Operating Versatility And Convenience At Lowest Cost. When the Hams at Heath design a rig, it always has the necessary features to do the job . . . and do it well. That's why the "102" has many of the "extra cost options" of other transceivers already built-in. VOX operation, for instance, which is optional at extra cost on many other transceivers, is built-into the "102". So is the CW sidetone, which allows you to monitor your code. The 100 kHz crystal calibrator is also designed in from the start, instead of having to be added at an extra-cost option. Phone Patch capability, which would require extensive modification on some other rigs is also built-in. The list of standard features on the "102" is very long . . . but all these items are necessary for smooth, efficient, enjoyable operations. Check this run-down of standard features against any other transceiver . . . complete coverage of the ten meter band without having to buy any additional crystals . . . switch-selected choice of either USB or LSB on all bands . . . auxiliary crystal control capability . . . front panel headphone jack . . . switch-selection of built-in 2.1 kHz or optional 400 Hz CW crystal filter . . . separate headphone volume control . . . two spare rear panel jacks for connection of other gear . . . choice of power supplies left to you, instead of being built-in.

Other Features Include compatibility with the most complete line of station accessories available . . . fast, enjoyable circuit board-wiring harness construction . . . handsome Heathkit SB-Series styling . . . and the flexibility of operation and reliability that have made the Heathkit SB-Series the world's most popular ham gear.

Check out the world's finest transceiver . . . the SB-102.

HEATH
Schlumberger

HEATH (GLOUCESTER) LTD
GLOUCESTER, GL2-6EE, ENGLAND

PRICES AND SPECIFICATIONS SUBJECT TO CHANGE WITHOUT NOTICE.

SPECIFICATIONS

RECEIVER

Sensitivity: Less than 0.35 microvolt for 10 dB signal-plus-noise to noise ratio for SSB operation. **SSB Selectivity:** 2.1 kHz minimum at 6 dB down, 5 kHz maximum at 60 dB down (3.395 MHz filter). (2:1 nominal shape factor at 60:6 dB.) **CW Selectivity (With SBA-301-2 CW Filter Installed):** 400 Hz minimum at 6 dB down, 2.0 kHz maximum at 60 dB down. **Input:** Low impedance for unbalanced coaxial input. **Output Impedance:** 8 Ω speaker, and high impedance headphone. **Power Output:** 2 watts with less than 10% distortion. **Spurious Response:** Image and IF rejection better than 50 dB. Internal spurious signals below equivalent antenna input of 1 microvolt.

TRANSMITTER

DC Power Input: SSB: (A3J emission) 180 watt P.E.P. (normal voice: continuous duty cycle). CW: (A1 emission) 170 watts (50% duty cycle). **RF Power Output:** 100 watts on 80 through 15 meters: 80 watts on 10 meters (50 Ω nonreactive load). **Output Impedance:** 50 Ω to 75 Ω with less than 2:1 SWR. **Oscillator Feedthrough Or Mixer Products:** 55 dB below rated output. **Harmonic Radiation:** 45 dB below rated output. **Transmit-Receive Operation:** SSB: PTT or VOX. CW: Provided by operating VOX from a keyed tone, using grid-block keying. **CW Side-Tone:** Internally switched to speaker or headphones, in CW mode. Approximately 1000 Hz tone. **Microphone Input:** High impedance with a rating of -45 to -55 dB. **Carrier Suppression:** 50 dB down from single-tone output. **Unwanted Sideband Suppression:** 55 dB down from single-tone output at 1000 Hz reference. **Emissions not possible or not recommended:** A0, A2, A3, A3b, A4 through A9, F0 through F9, and P0 through P9. **Third Order Distortion:** 30 dB down from two-tone output. **RF Compression (TALC*):** 10 dB or greater at .1 mA final grid current.

GENERAL

Frequency Coverage: 3.5 to 4.0; 7.0 to 7.3; 14.0 to 14.5; 21.0 to 21.5; 28.0 to 28.5; 28.5 to 29.0; 29.0 to 29.5; 29.5 to 30.0 (megahertz). **Frequency Stability:** Less than 100 hertz per hour after 10 minutes warmup from normal ambient conditions. Less than 100 Hz for $\pm 10\%$ line voltage variations. **Modes Of Operation:** Selectable upper or lower sideband (suppressed carrier) and CW. **Visual Dial Accuracy:** Within 200 Hz on all bands. **Electrical Dial Accuracy:** Within 400 Hz after calibration at nearest 100 kHz point. **Dial Mechanism Backlash:** Less than 50 Hz. **Calibration:** 100 kHz crystal. **Audio Frequency Response:** 350 to 2450 Hz. **Phone Patch Impedance:** 8 Ω receiver output to phone patch; high impedance phone patch input to transmitter. **Front Panel Controls:** Main (LMO) tuning dial. Driver tuning and Preselector. Final tuning. Final loading. Mic and CW Level control. Mode switch. Band switch. Function switch. Freq Control switch. Meter switch. RF Gain control. Audio Gain control. Filter switch. **Internal Controls:** VOX Sensitivity. VOX Delay. Anti-Trip. Carrier Null (control and capacitor). Meter Zero control. CW tone volume. Relative Power Adjust control. Bias. Phone Vol (headphone volume). Neutralizing. **Tube Complement:** OA2 Regulator (150 V). 6HS6 RF amplifier. 6AU6 1st receiver mixer. 6AU6 Isolation amplifier. 6AU6 1st IF amplifier. 6AU6 2nd IF amplifier. 6BN8 Product detector and AVC. 6CB6 2nd transmitter mixer. 6CL6 Driver. 6EA8 Speech Amplifier and cathode follower. 6EA8 1st transmitter mixer and crystal oscillator. 6EA8 2nd receiver mixer and relay amplifier. 6EA8 CW side-tone oscillator and amplifier. 6GW8 Audio amplifier and audio output. 12AT7 Heterodyne oscillator and cathode follower. 12AT7 VOX amplifier and calibrator oscillator. 12AU7 Sideband oscillator. 6146 Final amplifiers (2). **Diode Complement:** 6 Germanium Diodes: Balanced modulator, RF sampling, and crystal calibrator harmonic generation. 10 Silicon Diodes: ALC rectifiers, Anti-Trip rectifiers, and DC blocking, LMO Power Supply. 2 Zener Diodes: Cathode bias, LMO Power Supply. **Transistor:** 2N3567 LMO Power Supply. **Rear Apron Connections:** CW Key jack. 8 Ω output. Phone patch input. ALC input. Power and accessory plug. RF output. Driver output. Spare A. Spare B. **Power Requirements:** 700 to 850 volts at 250 mA with 1% maximum ripple. 300 volts at 150 mA with .05% maximum ripple. -115 volts at 10 mA with .5% maximum ripple. 12 volts AC/DC at 4.76 amperes. **Cabinet Dimensions:** 14-7/8" wide x 6-5/8" high x 13-3/8" deep. **Net weight:** 17-1/2 lbs.

Assembly
and
Operation
of the



SSB TRANSCEIVER

MODEL SB-102

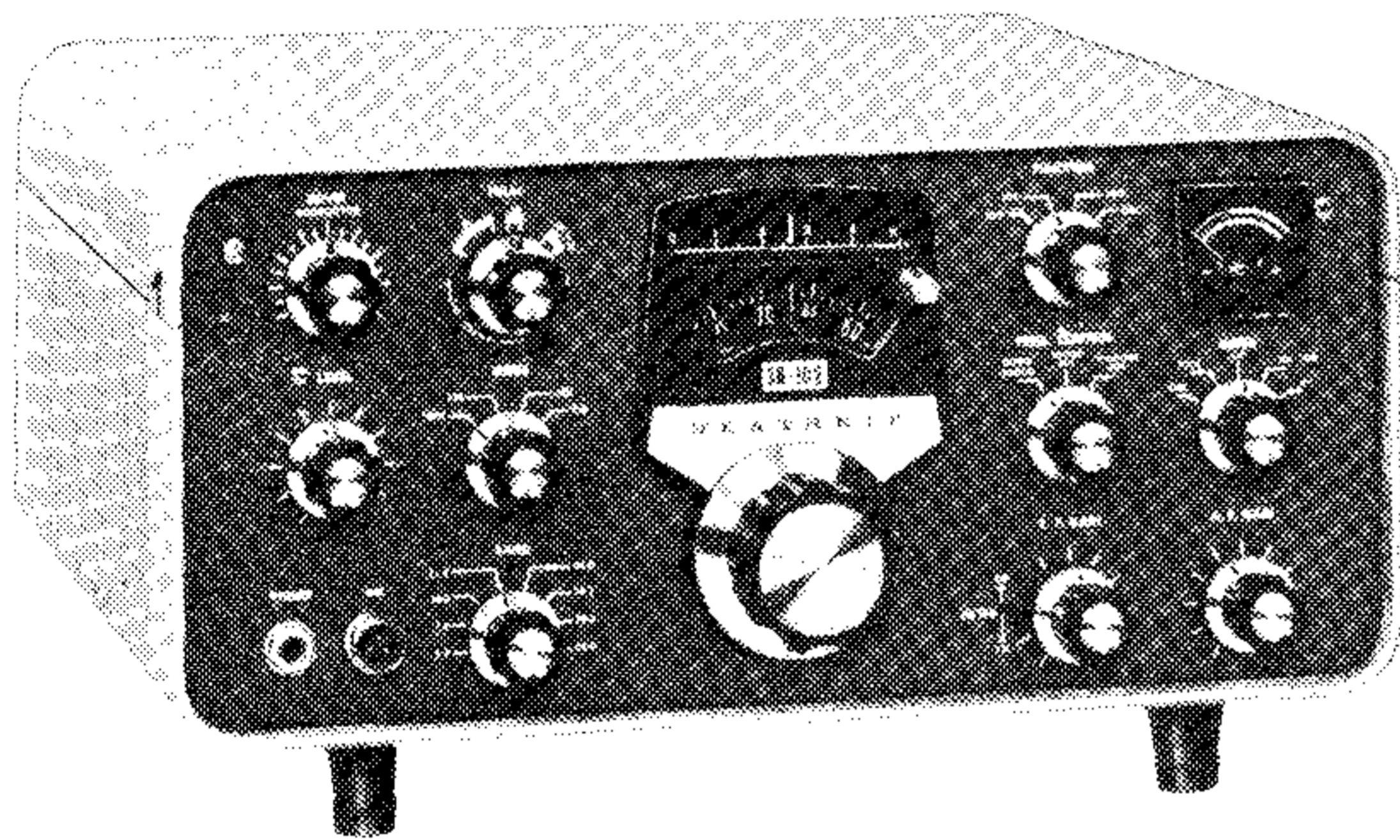

TABLE OF CONTENTS

Introduction.	2
Circuit Board Parts List.	3
Circuit Board Assembly.	5
Chassis Parts List.	22
Chassis Assembly	
Parts Mounting.	26
Harness Wiring.	38
Coaxial Cable Harness Wiring.	45
Component Mounting-Chassis	
Bottom.	49
Wiring RF Section-Chassis Top.	54
LMO Power Supply Chassis.	56
Dial Mounting.	60
Front Panel Parts Mounting.	63
Front Panel Wiring.	64
Front Panel Mounting.	68
Chassis Top Wiring.	70
Final Wiring-Chassis Bottom.	78
Knob Installation.	87
Control Functions.	88
Preliminary Checks.	90
Power Supply Connections.	98
Initial Test.	100
Alignment.	101
Special Crystal Considerations.	106
Cabinet Installation.	108
Installation.	110
Noise Suppression Troubleshooting	
Chart.	115
Operation.	116
Voltage Charts*.	122
In Case Of Difficulty.	122
Resistance Chart*.	123
Troubleshooting Chart.	123
Specifications	131
Circuit Description	135
Chassis Photographs.	156
Circuit Board X-Ray Views	158
Replacement Parts Price List	162
Schematic*.	165
*(fold-out from page)	
Warranty	Inside front cover
Customer Service	Inside back cover

HEATH COMPANY
BENTON HARBOR, MICHIGAN 49022

CONTROL FUNCTIONS

The functions of the front panel and chassis controls are outlined in this section. Read the following paragraphs carefully, so you will be familiar with the operation of each control before starting to check, align, or operate this Transceiver.

FRONT PANEL FUNCTIONS

Driver Preselector

This control is used to peak the receiver RF amplifier and transmitter driver tuned circuits. The adjustment can be made in either the receive or transmit mode of operation, and must be adjusted at each position of the BAND switch. This adjustment should also be made when the operating frequency is changed appreciably.

Mic/CW Level

When the MODE switch is in the LSB or USB position, this control is used to adjust the audio drive. The control has range enough to adjust for most high-level crystal or dynamic microphones.

With the MODE switch in the Tune or CW position, the carrier output level of the transmitter is adjusted with this control.

Phones

High impedance headphones can be connected to this jack. When the headphone plug is inserted, the speaker is disconnected from the circuit.

Mic (Microphone)

A high-impedance microphone should be connected to this socket. Provisions are made in the socket for connecting a microphone with a push-to-talk switch.

Final

The round knob is the FINAL tuning control, and the panel markings are for the 80-meter through 10-meter bands. After the MAIN TUNING control has been set to the desired operating frequency, and the MODE switch set to the TUNE position, this control is adjusted for maximum (Relative Power) meter indication to tune the transmitter for maximum output.

The lever arm is the FINAL loading control. It is also tuned for a maximum (Relative Power) meter indication. At this point, there is a proper impedance match between the final amplifier circuit and the antenna.

The FINAL Tuning and FINAL loading controls have some interaction and must be adjusted alternately until maximum relative power is achieved.

Mode

This switch selects the LSB, USB, or CW mode of operation for the receive and transmit sections. In the TUNE position, the transmitter is turned on so the driver and final RF stage can be tuned.

Band

In the first four switch positions, this switch selects the following bands: 80-meter (3.5 MHz to 4.0 MHz), 40-meter (7.0 MHz to 7.5 MHz), 20-meter (14.0 MHz to 14.5 MHz), and 15-meter (21.0 MHz to 21.5 MHz).

The following 500 kHz portions of the 10-meter band are selected in the other four positions of this switch: 28.0 MHz to 28.5 MHz, 28.5 MHz to 29.0 MHz, 29.0 MHz to 29.5 MHz, and 29.5 MHz to 30.0 MHz.

Filter Switch

This switch selects either the SSB crystal filter or, if installed, the accessory CW crystal filter.

Main Tuning

The MAIN TUNING (LMO) has two dials; the lower (circular) and upper (straight) dials.

The lower or circular dial is divided into one-hundred 1 kHz segments. The upper or straight dial is numbered from 0 to 5, and is divided into five 100 kHz segments. The distance between any two consecutive numbers is equal to 100 kHz or one revolution of the circular dial. Each large segment is divided into two 50 kHz segments, each equal to one-half of a revolution of the circular dial.

The frequency setting of the MAIN TUNING dial is determined by adding three numbers together as follows: the BAND switch setting in megahertz, the upper dial setting in hundreds of kilohertz, and the circular dial setting in kilohertz.



Example #1

BAND switch set at 7.0	7.0 MHz
Upper dial pointer between 2 and 3	200 kHz
Circular dial pointer at 26	26 kHz
Transceiver frequency	7.226 MHz

Example #2

BAND switch set at 28.5	28.5 MHz
Upper dial pointer between 3 and 4	300 kHz
Circular dial pointer at 74	74 kHz
Transceiver frequency	28.874 MHz

Zero Set Dial

This control adjusts the position of the zero set line when the dial is calibrated. First, the MAIN TUNING control is adjusted for a zero beat with the 100 kHz calibrate signal. Then the Zero Set knob is turned until the zero set line is over the zero mark on the circular dial. The Zero Set Dial should be adjusted at each new setting of the BAND switch. NOTE: On the higher bands, extra signals may be heard in the CAL position. The correct ones should be quite near "0", and can be peaked with the DRIVER PRESELECTOR.

Function

This switch turns the Transceiver OFF, or turns it on when set at the PTT (push-to-talk), VOX (voice-operated-transmit), or CAL (calibrate) positions.

In the PTT position, the Transceiver is changed from receive to transmit operation by using a push-to-talk microphone switch, or a CW key. The MODE switch must be set at LSB or USB for push-to-talk operation, or at CW when using a CW key.

In the VOX position, the Transceiver is changed from receive to transmit operation when the operator talks into the microphone, or when the CW key is depressed (depending on the MODE switch position).

In the CAL position, the 100 kHz crystal oscillator signal is turned on to calibrate the Main Tuning dial at 100 kHz intervals.

FREQ CONTROL

At the LOCKED NORMAL position of this switch, the receiver and transmitter operating frequencies are determined by the linear master oscillator. The linear master oscillator frequency is determined by the setting of the MAIN TUNING control.

In the LOCKED AUX position, the auxiliary crystal and crystal oscillator tube V5B determine the receiver and transmitter operating frequency.

In the UNLOCKED AUX position, the auxiliary crystal and crystal oscillator tube V5B determine only the transmitter frequency. The receiver frequency is set with the MAIN TUNING (LMO) control.

RF Gain

The receiver sensitivity is controlled by the RF GAIN control. This control is set at the full clockwise position for maximum gain.

Meter

In the receive mode of operation, the METER switch is normally set at the ALC position. Then the meter is connected as an S-Meter that reads from 0 to 60 dB over S-9.

In the transmit mode of operation, the METER switch selects one of the following five measurements to be read on the meter: final amplifier Grid current (0 to 1 mA), final amplifier Plate current (0 to 500 mA), Automatic Level Control, Relative (output) Power, and High Voltage on the B+ line (0 to 1000 volts DC).

AF Gain

The AF GAIN control adjusts the audio output in the receive mode of operation.

CHASSIS FUNCTIONS

VOX Sen

The VOX SEN (Vox Sensitivity) control adjusts the VOX relay circuit to operate at the voice level desired by the operator. When the operator talks into the microphone, the VOX relay is energized and places the transmitter "on-the-air."

VOX Delay

This control adjusts the length of time the transmitter stays on after the operator stops talking (when the FUNCTION switch is set at VOX). Proper setting of the VOX DELAY control eliminates repeated keying of the transmitter at the beginning of each word.

Anti-Trip

The ANTI-TRIP control adjusts the VOX circuit to keep the received signal (at the speaker) from turning on the transmitter by feedback into the microphone.

Meter Zero

The METER ZERO control is adjusted for a zero reading on the meter in the receive mode of operation with no signal being received and with the RF GAIN control turned fully clockwise.

Carrier Null Control

This control balances the modulator to suppress the carrier.

Carrier Null Capacitor

The CARRIER NULL CAPACITOR is adjusted to complete the modulator balance.

Cal Xtal

This trimmer adjusts the 100 kHz oscillator to exactly 100 kHz.

Aux Trim

This trimmer permits the frequency of the auxiliary crystal oscillator to be adjusted a small amount.

CW-Tone Volume

With the MODE switch set to CW and with the CW key depressed, the CW-TONE VOLUME control adjusts the CW tone to the desired monitoring level from the speaker.

Phone VOL

The Phone Volume control is adjusted to obtain the desired balance between the speaker and headphone levels.

Bias Adjust

This control adjusts the bias voltage on the final RF amplifier tubes when the MIC/CW LEVEL control is turned fully counterclockwise.

Relative Power

The Relative Power control adjusts the meter sensitivity when the METER switch is in the REL PWR position.

Antenna

The built-in antenna relay switches the common receiving and transmitting antenna at the RF out connector from the receiver to the transmitter sections.

The DRIVER OUTPUT connector is used with the Heathkit Model SB-500 Transverter.

PRELIMINARY CHECKS

Before applying power to the Transceiver, complete the preliminary checks as outlined in this section. These checks are needed to be sure there are no short circuits or open connections that would cause damage to the Transceiver components.

- () Check the position of the pointer on the panel meter. If necessary, adjust the screw at the front of the meter until the pointer is on zero.

- () Turn the following front panel controls to a fully counterclockwise position.

DRIVER PRESELECTOR control
 MIC/CW LEVEL control
 MODE switch
 BAND switch
 FUNCTION switch
 FREQ CONTROL
 RF GAIN control
 METER switch
 AF GAIN control
 FILTER switch

- () Set the following chassis controls to a fully counterclockwise position. Refer to Figure 1-1 (fold-out from Page 88) to help locate the controls.

VOX SEN
 VOX DELAY
 ANTI-TRIP
 CARRIER NULL control
 METER ZERO
 CW-TONE VOLUME
 PHONE VOL
 BIAS ADJUST
 RELATIVE POWER

METER CIRCUIT CHECKS

Refer to Figure 1-2 (fold-out from Page 107) to locate the test points for the following checks.

An ohmmeter will be used for the following checks. When making the first check, the polarity of the ohmmeter test leads will be determined. Then the test points for the common and positive (+) leads will be called out in each step.

- () Set the ohmmeter to the RX1 range.
- () Turn the front panel METER switch to the PLATE position.
- () Check the polarity of the ohmmeter leads as follows: Connect one ohmmeter lead to the Transceiver chassis and the other lead to pin 1 of tube socket V9. If an "up scale" deflection of the front panel meter is not obtained, reverse the ohmmeter leads. When an "up scale" meter indication is obtained on the front panel meter, the ohmmeter lead connected to pin 1 of tube socket V9 should be marked (+) positive. This lead should be used as the positive (+) lead for the remaining checks.

NOTE: If the correct results are not obtained in the following steps, refer to the In Case Of Difficulty section on Page 122. It is suggested that all the checks be completed before doing any troubleshooting. The resistance readings may set some pattern that will make the difficulty easier to locate.

Complete each of the following checks by connecting the ohmmeter leads as indicated. Set the METER switch and the ohmmeter range as listed in the step. For each check, the panel meter should indicate in an "up scale" direction.

METER SWITCH	OHMMETER RANGE	COMMON LEAD	POSITIVE (+) LEAD
(✓) GRID	RX10	Pin 5 of tube socket V9	Chassis
(✓) ALC	RX1	Pin 7 of tube socket V3 (on IF circuit board)	Chassis
(✓) REL PWR	RX1	Chassis	Lug 1 of terminal strip BH
(✓) HV	RX100	Chassis	Lug 1 of terminal strip BK

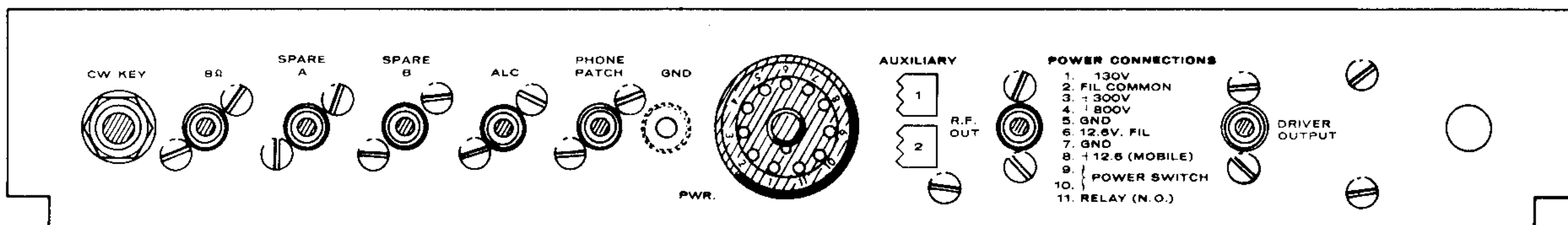

Figure 1-3

RESISTANCE CHECKS

Refer to Figure 1-1 (fold-out from Page 88), 1-2 (fold-out from Page 107) and 1-3 for the following resistance checks.

Complete the resistance checks listed in each of the three charts. Connect the common and positive (+) ohmmeter leads and set the switches as listed in the chart.

When more than one switch setting is given, make the resistance check at each setting of the switch. Also, observe the special instructions given in the NOTES column.

NOTE: If any incorrect resistance readings ($\pm 20\%$ from the listed value) are obtained, refer to the In Case Of Difficulty section and correct the trouble before proceeding.

IMPORTANT: The word "Diode" in the NOTES column of the following charts indicates that a diode is in the circuit under test. Therefore, the measured resistance can vary due to the forward current of the diode, depending on the range setting of the ohmmeter. The ohmmeter readings in the chart were made with a VTVM. Readings made with a VOM will be considerably different from those listed.

OHMMETER TEST POINTS		MODE SWITCH	RESISTANCE IN OHMS	NOTES
COMMON LEAD	POSITIVE (+) LEAD			
(✓) Chassis	CW KEY jack, lug 3	CW	50k	
(✓) CW KEY jack, lug 3	Chassis	"	30k	(Diode)
(✓) "	"	TUNE, LSB, and USB	80k	(Diode)
(✓) Chassis	8 Ω jack, lug 2	TUNE	.7	
(✓) "	Spare A jack, lug 2	"	INF	
(✓) "	Spare B jack, lug 2	"	INF	
(✓) "	ALC jack, lug 2	"	5 to 100	(Diode)
(✓) ALC jack, lug 2	Chassis	TUNE and CW	20k	(Diode)
(✓) "	"	LSB and USB	3M	(Diode)
(✓) Chassis	Phone Patch jack, lug 2	TUNE	1M	
(✓) "	Power plug, Pin 1	"	13k	
(✓) "	" Pin 2	"	0	



OHMMETER TEST POINTS		MODE SWITCH	RESISTANCE IN OHMS	NOTES
COMMON LEAD	POSITIVE (+) LEAD			
() Chassis	Power plug, Pin 3	TUNE, USB, CW	35k	
(✓) "	" Pin 3	LSB	25k	
(✓) "	Power plug, Pin 4	TUNE	1M	
(✓) "	" Pin 5	"	0	(Ground)
(✓) "	" Pin 6	"	1	
(✓) "	" Pin 7	"	0	
(✓) "	" Pin 8	"	50k	(Diode)
(✓) "	" Pin 9	"	INF	
(✓) "	" Pin 10	"	INF	
(✓) "	" Pin 11	"	INF	
(✓) Power plug, Pin 9	" Pin 10	"	INF	
(✓) " "	" "	"	0	Check at three positions of FUNCTION switch: PTT, VOX and CAL. Then return the FUNCTION switch to the OFF position.
() Chassis	RF OUT jack, lug 2	"	.2	
(✓) "	PHONES jack, contact 5	"	.2 through 2000 to 3	Varies with setting of PHONE VOL control.
(✓) "	MIC socket, lug 1	"	1M	
(✓) "	" lug 2	"	0	
(✓) "	" "	LSB, USB, and CW	500k	
() "	RF GAIN control, lug 2	TUNE	70k to 10	Varies with setting of RF GAIN control.
(✓) "	AF GAIN control, lug 2	"	8 to 500k	Varies with setting of AF GAIN control.

OHMMETER TEST POINTS		BAND SWITCH	RESISTANCE IN OHMS
COMMON LEAD	POSITIVE (+) LEAD		
(✓) Chassis	Capacitor lug DB-1	3.5 and 7.0	11k
(✓) "	" " "	14.0 through 29.5	INF
	<u>CIRCUIT BOARD LOCATION</u>		
(✓) Power plug, Pin 3	RF DRIVER Foil 7	3.5	100
(✓) "	" 3	"	100
(✓) "	" 3	7.0 through 29.5	22k
(✓) "	" 9	3.5	1000
(✓) "	" 4	"	1000
(✓) "	" 4	7.0 through 29.5	INF
(✓) Chassis	Lug 1 (Wafer BS1 of BAND switch)	3.5	4700
(✓) "	"	7.0 through 29.5	INF
(✓) Audio Circuit Board 22	Bandpass Circuit Board B	All Positions	100

OHMMETER TEST POINTS		MODE SWITCH	FREQUENCY CONTROL SWITCH	RESISTANCE IN OHMS	NOTES
COMMON LEAD	POSITIVE (+) LEAD				
(✓) Chassis	CIRCUIT BOARD LOC. Bandpass H	TUNE	LOCKED NORMAL and UN-LOCKED AUX	.3	
(✓) "	" H	"	LOCKED AUX	INF	
(✓) "	" F	"	LOCKED NORMAL	100	
(✓) "	" F	"	LOCKED AUX and UN-LOCKED AUX	INF	
(✓) "	" G	"	LOCKED NORMAL	INF	
(✓) "	" J	"	"	150k	
(✓) Audio Circuit Board 22	" 19	"	LOCKED NORMAL and UN-LOCKED AUX	INF	
(✓) " 22	" 19	"	LOCKED AUX	0	
() Chassis	CIRCUIT BOARD LOC. Audio 22	"	"	45k	35k
() "	" "	"	LOCKED NORMAL and UN-LOCKED AUX	35k	28k
() Chassis	CIRCUIT BOARD LOC. Bandpass E	"	LOCKED NORMAL	35k	28k
(✓) "	" 8	"	"	100k to 600k	Varies with setting of VOX SEN control.
(✓) "	" 8	CW	"	0	
(✓) "	" D	TUNE, USB, LSB	"	0 to 500k	Varies with setting of VOX SEN control.
(✓) "	" "	CW	"	0 to 100k	"
(✓) "	Modulator E	"	"	20Ω to 1M	Varies with setting of ANTI-TRIP control. (Diode)

OHMMETER TEST POINTS			MODE SWITCH	FREQUENCY CONTROL SWITCH	RESISTANCE IN OHMS	NOTES
COMMON LEAD	POSITIVE (+) LEAD					
(✓) Chassis	CIRCUIT BOARD	LOC.	TUNE	LOCKED NORMAL	2M to 12M	Varies with setting of VOX DELAY control.
(✓) "	Bandpass	14	"	"	0	
(✓) "	"	16	LSB, USB, and CW	"	500k	
(✓) "	Bandpass	3	TUNE	LOCKED NORMAL	INF	Goes to "0" in "CAL" position of FUNCTION switch.
() "	"	C	"	"	35k	25k
(✓) "	IF	B	"	"	4700	
() "	IF	13	"	"	10 Ω to 100k	(Diode) Varies with setting of RF GAIN control.
(✓) "	Audio	B	"	"	1M to 100k	Varies with setting of ANTI-TRIP control.
(✓) "	Modulator	21	TUNE, USB, and CW	LOCKED NORMAL	INF	
(✓) "	"	21	LSB	"	100k	
(✓) "	" Socket V16 Pin1		LSB	"	INF	
(✓) "	" Socket V16 Pin 1		TUNE, USB, and CW	"	70k	
(✓) "	"	D	TUNE	"	20 Ω to 500k	Varies with setting of MIC/CW LEVEL control.
() "	SSB BIAS (terminal at rear of LMO)		TUNE, USB, and CW	"	10 k to 12 k	Varies with setting of BIAS adjust control.
() "	"		LSB	"	10 k to 12 k	

This completes the Preliminary Checks.

COIL COVER INSTALLATION

Refer to Pictorial 3-27 for the following steps.

- () Install the eight spring clips on the coil cover with 3-48 x 3/8" hardware. Position the spring clips as shown. Bend the clip ends down slightly as shown in the inset drawing.

CAUTION: Be sure that none of the lugs of the switch wafers that are mounted on the driver plate, driver grid, heterodyne oscillator, and crystal circuit boards extend beyond the edges of these circuit boards.

- () Refer to Detail 3-27A and mount the coil cover on the bottom of the chassis with #6 x 3/8" sheet metal screws (screws from the RF cage). Be sure the spring clips on the coil cover fit on each side of the two switch shields. Note that the edge of the coil cover must first be positioned under the support rail, before the coil cover can be positioned into place. This can be checked by looking at the ends of the circuit boards from under the support rail.

- () Check the resistance between pin 3 of the power plug and the chassis. A zero resistance reading indicates a short circuit caused by the coil cover touching one or more of the switch lugs. This condition must be corrected before turning on the Transceiver.

TUBE INSTALLATION

- () Install the remaining tubes in their sockets, as identified on the circuit boards and Figure 1-1.

Install the tube shields as follows:

- () Small tube shield (1-3/4" long) at V6.
- () Large tube shield (2" long) at V7.
- () Large tube shield (1-3/4" long) at V1.

Refer to the Special Crystal Considerations section of the Manual on Page 106, for the crystal that may be used in the Auxiliary Crystal socket on the bandpass circuit board.

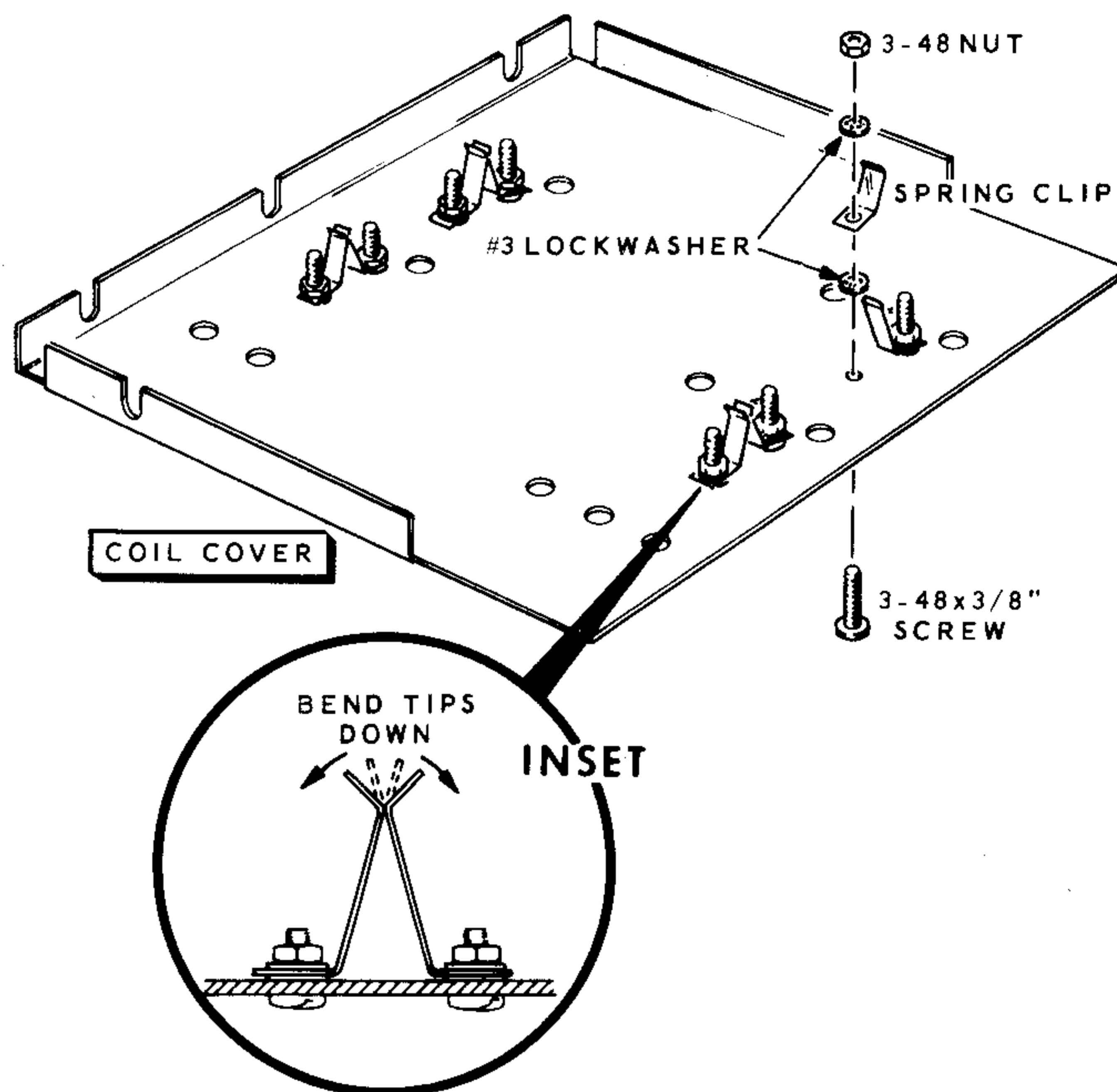

PICTORIAL 3-27

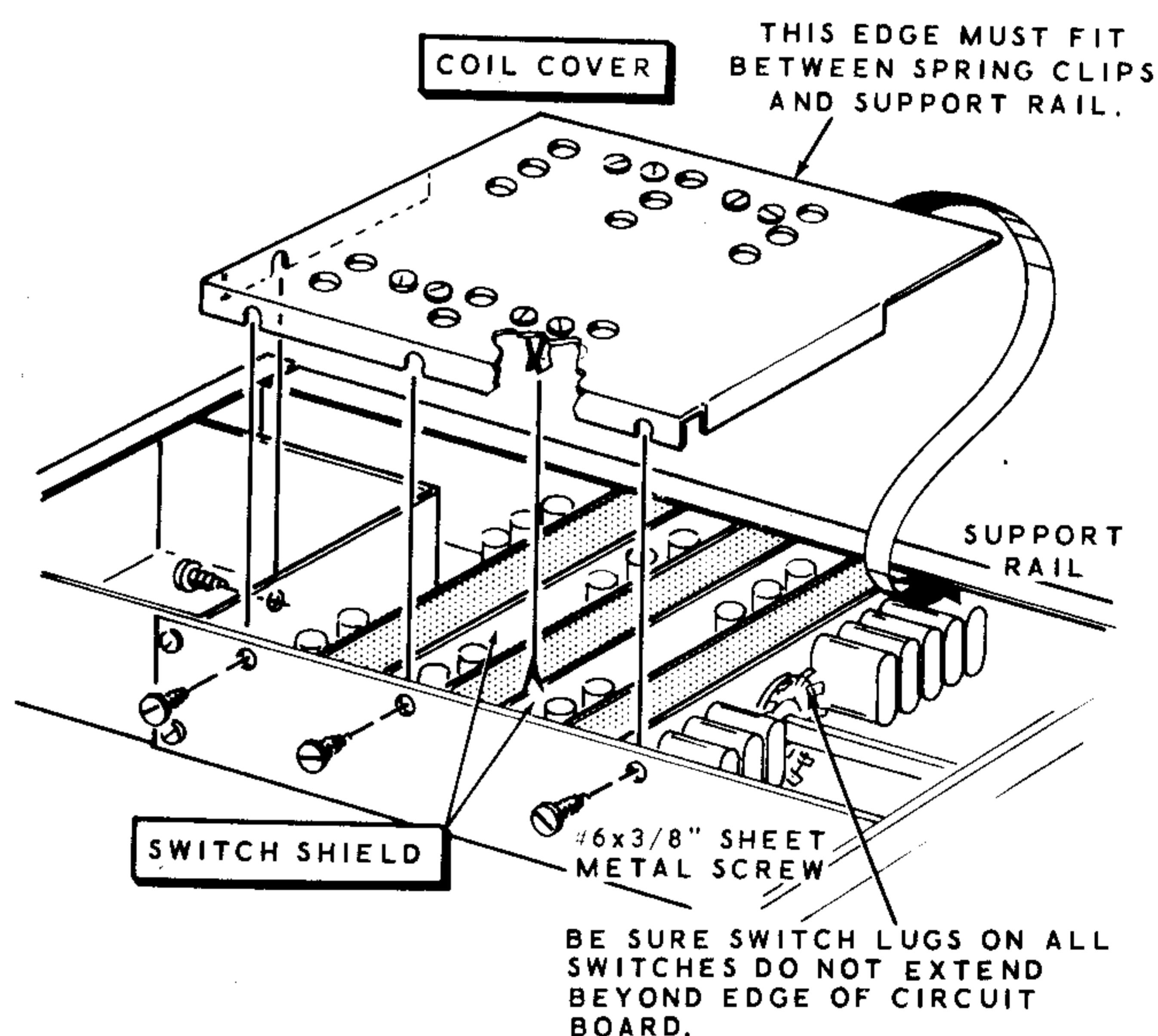

Detail 3-27A

POWER SUPPLY CONNECTIONS

The Transceiver was designed to operate with the Heathkit Models HP-13 or HP-13A (12 VDC power source) and HP-23 or HP-23A (117 V AC power source) Power Supplies. The following information will help you wire the 11-pin socket (supplied with the Transceiver) for the power cable of the Power Supply you intend to use.

HP-13A POWER SUPPLY CONNECTIONS

CAUTION: Be sure the alternate connection in the low voltage DC circuit of the HP-13A Power Supply is connected for +300 volts output as outlined in the HP-13A Manual. Be sure the automobile voltage regulator is set to less than 14.5 volts.

NOTE: If the Heathkit Model SBA-100-1 Mobile Mount is used, complete the power supply connections as directed in that manual.

Refer to Figure 1-4 for the following steps.

- () Install the 11-pin socket cap over the free end of the 8-wire cable from the HP-13A Power Supply, as shown.
- () Remove 3/4" of the outer insulation from the end of the 8-wire cable. Then remove 1/4" of insulation from the end of each wire.

- () Melt a small amount of solder on each of the exposed wire ends to hold the small strands of wire together.
- () Insert the lead from the cap end of the fuseholder (an in-line fuseholder with lead is supplied with the HP-13A Power Supply) through the socket cap as shown.
- () Cut seven 5/8" lengths of large sleeving and slip them over the indicated wires.
- () Connect a 1/2" white wire between lugs 8 (S-1) and 6 (NS) of the 11-pin socket.
- () Connect the wires of the 8-wire cable, and the fuseholder lead, to the 11-pin socket lugs as shown. Solder each connection.

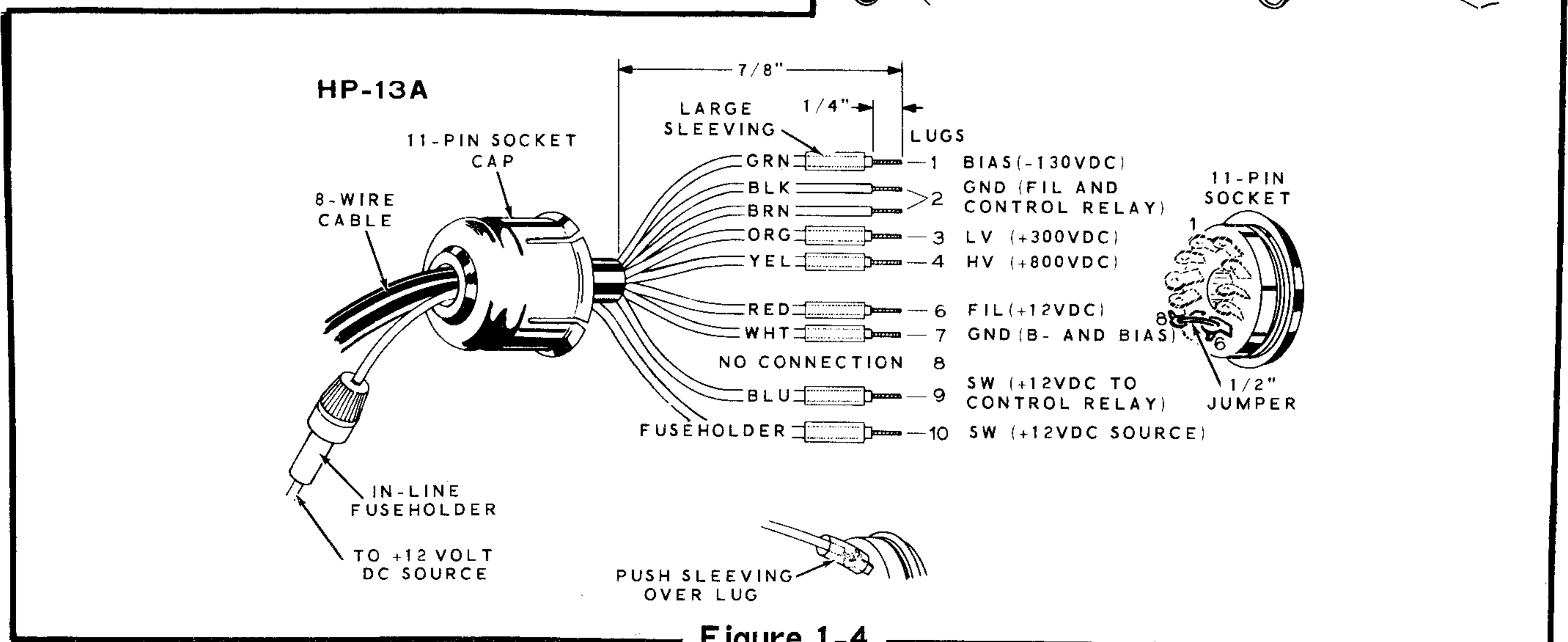

Figure 1-4

- () Push the lengths of sleeving over the lugs of the socket.
- () Snap the socket cap onto the 11-pin socket. **IMPORTANT:** When using the HP-13A Power Supply with the Transceiver, be sure the Bias control of the Power Supply is in its fully clockwise position. This setting will supply a maximum bias voltage at pin 9 of the power socket.
- () Peel the backing paper from the filament warning label and press the label into place on the 11-pin socket cap as shown.

- () Melt a small amount of solder on each of the exposed wire ends to hold the small strands of wire together.

For the SB-200 and other Linear Amplifiers, use a piece of coaxial cable through the cap to bring out the relay connections.

- () Cut seven 5/8" lengths of large sleeving and slip them over the indicated wires.
- () Connect the wires of the 8-wire cable and the coaxial cable (if a Linear Amplifier is used) to the 11-pin socket lugs as shown. Solder each connection.

NOTE: SB-100, SB-101, and HW-100 Transceivers that use this power socket will require removal of any wire connected to pin 8.

- () Push the lengths of sleeving over the lugs of the socket.

- () Snap the socket cap onto the 11-pin socket.

HP-23A POWER SUPPLY CONNECTIONS

CAUTION: Be sure the alternate connection in the low voltage DC circuit of the HP-23A Power Supply is connected for +300 volts DC output as outlined in the HP-23A Manual.

NOTE: With the above connections, the BIAS control in the HP-23A Power Supply is inoperative. Proper bias settings are accomplished with the BIAS control in the Transceiver.

Refer to Figure 1-5 for the following steps.

- () Install the 11-pin socket cap over the free end of the 8-wire cable from the Power Supply.
- () Remove 7/8" of the outer insulation from the end of the 8-wire cable. Then remove 1/4" of insulation from the end of each wire.

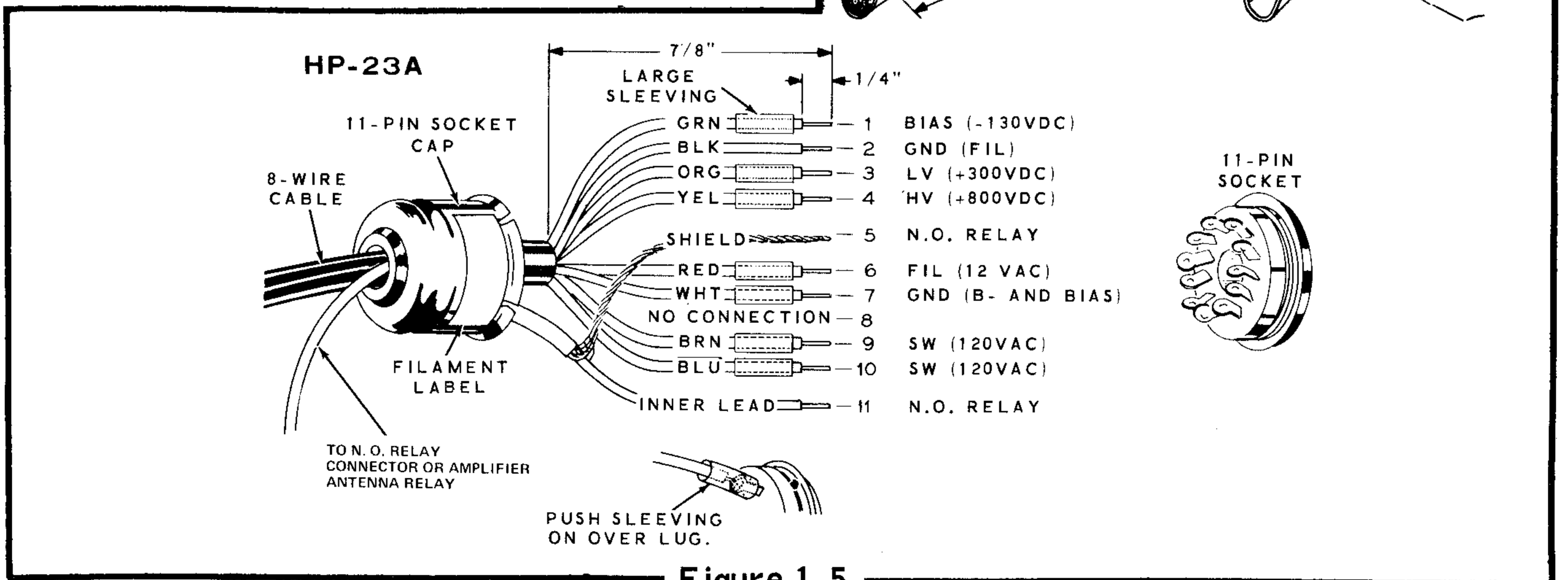
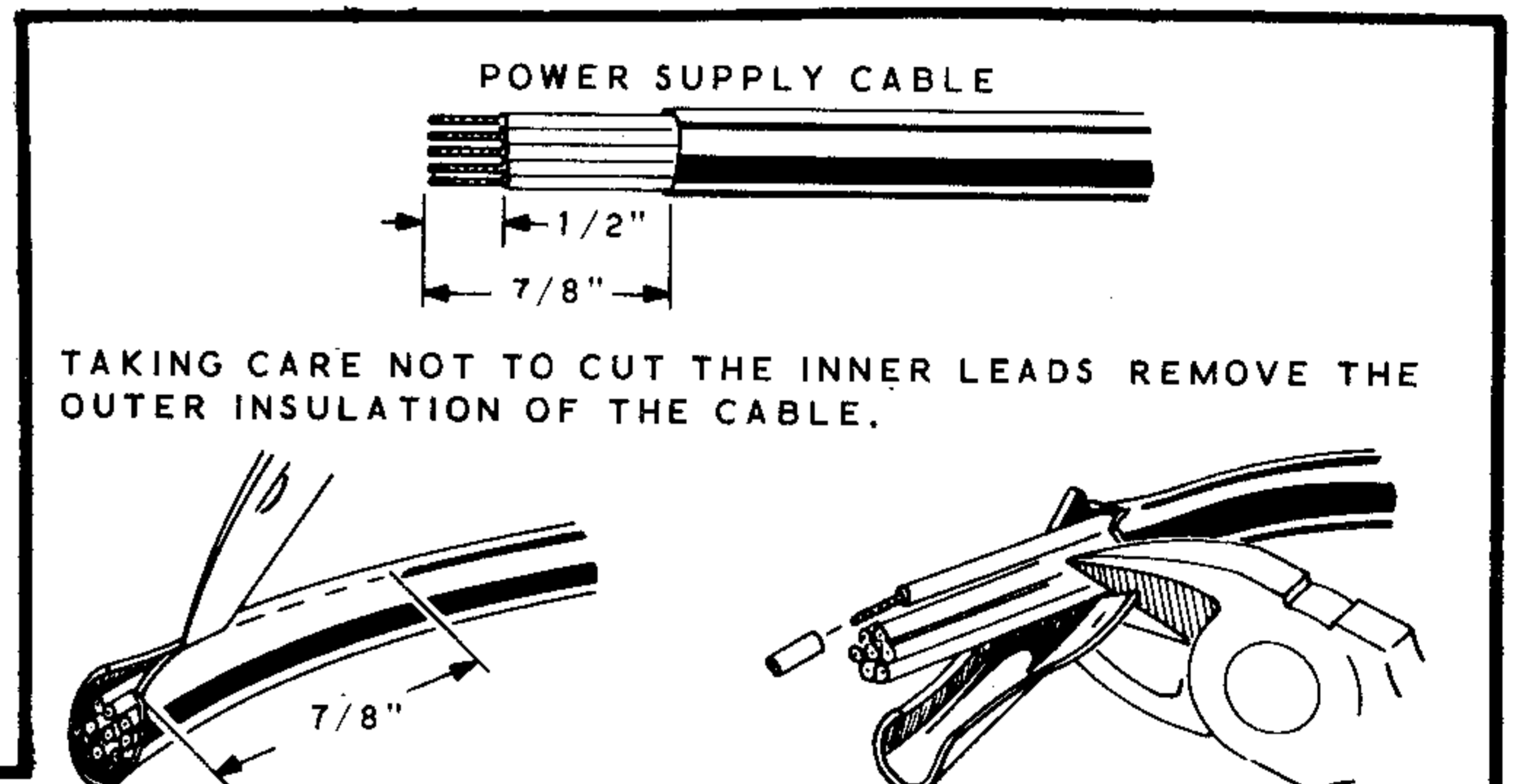

Figure 1-5

INITIAL TEST

CAUTION: BEFORE APPLYING POWER TO THE TRANSCEIVER, NOTE THAT LETHAL VOLTAGES ARE PRESENT BOTH ABOVE AND BELOW THE CHASSIS. DO NOT TOUCH ANY HIGH VOLTAGE POINTS WITH YOUR HANDS. USE WELL INSULATED TOOLS FOR ANY ADJUSTMENTS ON THE CHASSIS.

TO LESSEN THE SHOCK HAZARD, CONNECT A LEAD FROM A GOOD EARTH GROUND TO THE GROUND BOLT LOCATED ON THE REAR OF THE CHASSIS AND TO ALL TEST EQUIPMENT.

- () Set the front panel controls as follows:
 - FINAL (round knob) to 80.
 - FINAL (lever knob) .. over the 50 Ω marking.
 - MODE. LSB.
 - RF GAIN. fully clockwise.
 - FILTER. SSB.
 - () Set the remaining front panel controls fully counterclockwise.
 - () Set the BIAS ADJUST control (on top of the chassis) fully counterclockwise.
 - () Connect the socket on the power supply cable to the Transceiver power plug.
 - () Connect the power supply to the proper power source.
 - () Connect an 8 Ω speaker to the 8 Ω socket at the rear of the Transceiver. CAUTION: Never operate the Transceiver unless a speaker or headphones are connected. For safety reasons, it is not recommended that headphones be used during the testing of the Transceiver.
 - () Be sure the 9-terminal cable connector with its jumper wire is positioned on the 9-terminal chassis connector.
- If abnormal operation is encountered at any time during the following tests, turn the Transceiver off immediately, and refer to the In Case Of Difficulty section of the Manual on Page 122.
- () Turn the FUNCTION switch to PTT. The panel lamps should now light with equal brilliance. The lamp in the LMO power supply should glow dimly.
 - () Turn the METER switch to HV. The panel meter should indicate +800 to +900 volts.
 - () Visually check all parts for any signs of overheating, and check to see that each tube filament glows.
 - () Turn the METER switch to PLATE. The panel meter should indicate zero.
 - () Turn the AF GAIN control in a clockwise direction until noise is heard from the speaker. NOTE: If no noise is heard, check to be sure the transmitter is not keyed by a depressed switch on a PTT microphone, or a closed key.
- Check the voltages listed in the next two steps with a voltmeter. Refer to Figure 1-2 (fold-out from Page 107) for the location of test points.
- () +300 volts DC from point 5 on the bandpass circuit board to chassis ground.
 - () -111 volts DC (bias) from point 4 on the audio circuit board to chassis ground.

ALIGNMENT

The coils and transformers in your Transceiver have been preset at the factory. Only slight readjustments should be necessary during the following alignment procedure.

The following equipment is necessary for alignment of the Transceiver.

1. A high impedance input voltmeter or a 20 k Ω /V VOM may be used.
2. A 50 Ω nonreactive dummy load that is capable of 100 watts dissipation. Do not use light bulbs as a dummy load, as their resistance varies radically with voltage.
3. A receiver capable of receiving WWV, at 2.5, 5, 10, or 15 MHz. If this type of receiver is not available, a receiver tunable to a standard broadcast station that is operating at an even multiple of 100 kHz (such as 600 kHz, 1000 kHz, etc.) can be used.

For the alignment of the transmitter section it is recommended that you use a Heathkit monitor scope to observe the output RF envelope.

WARNING: Do not place the Transceiver in the transmit mode of operation until directed to do so or the Transceiver may be seriously damaged.

- () Connect a 50 Ω dummy load, capable of 100 watts dissipation, to the RF OUT jack on the rear of the chassis. CAUTION: Do not use light bulbs as a dummy load.
- () Be sure an 8 Ω speaker is connected to the 8 Ω jack on the rear of the chassis.
- () Preset the CAL XTAL trimmer so its notch is towards the 100 kHz crystal as shown in Figure 1-1 (fold-out from Page 88).

- () Preset the front panel controls as follows:

DRIVER PRESELECTOR - 12 o'clock position (3.7, 14.2).

MIC/CW LEVEL - fully counterclockwise.

MODE - LSB

BAND - 3.5

Main tuning dial (LMO) - 3.7 MHz (upper dial pointer at 2, and the circular dial at 0).

FUNCTION - PTT.

FREQ CONTROL - LOCKED NORMAL.

RF GAIN - fully clockwise.

FILTER - SSB.

METER - ALC.

AF GAIN - 9 o'clock position.

S-METER ADJUSTMENT

- () After a few minutes warmup, adjust the METER ZERO control (on the IF circuit board directly behind the FREQ CONTROL switch) for a zero reading on the panel meter.

RECEIVER ALIGNMENT

- () Set the voltmeter switches so the meter will indicate a negative (-) DC voltage.
- () Connect the common lead of the voltmeter to the chassis and the other lead to the circuit board foil at TP on the screened side of the bandpass circuit board near tube V19. If your meter reads 0 at TP, contact instead the adjacent lead of the 100 k Ω (brown-black-yellow) resistor. A reading of -.3 V indicates that the oscillator is not operating.

The heterodyne oscillator output will be checked at each position of the BAND switch in the following steps. If necessary, the heterodyne oscillator coils will be adjusted to obtain a preliminary output voltage reading. Final adjustment will be made later.

- () With the BAND switch at 3.5, the voltmeter should indicate about -0.5 to -2 volts DC. If necessary, adjust coil 3.5 (near tube V11 on the top side of the RF-driver circuit board) to bring the voltage into this range. NOTE: When adjusting this coil in one direction, the oscillator output voltage will change rapidly; when adjusting the coil in the opposite direction from the peak, the output voltage will change slowly. Adjust the coil in the direction that gives the slower change in output voltage.
- () Similarly, check the heterodyne oscillator output voltage at all positions of the BAND switch. If necessary, adjust the correct heterodyne oscillator coil for any BAND switch position that does not give an indication of about -0.5 to -2 volts DC on the voltmeter. The heterodyne oscillator coils for bands 3.5, 14, and 28.5 are marked, and adjusted at the top side of the RF-driver circuit board; the coils for the other bands are marked on the shield cover, and are adjusted from the bottom of the chassis.
- () Set the FUNCTION switch to CAL and the BAND switch to 3.5; then turn the MAIN TUNING dial back and forth around 3.7 MHz to get the loudest signal. Check for the calibrate signal by turning the FUNCTION switch to VOX and back to CAL; the signal should stop and then start again and should peak with the DRIVER PRESELECTOR.
- () Reset the DRIVER PRESELECTOR to the 12 o'clock position.
- () Disconnect the voltmeter leads from the Transceiver.

The S-Meter will be used as an output indicator during the remaining alignment of the Transceiver, and the 100 kHz calibrator will be used as a signal source.

When adjusting the transformers in the following steps, use the large end of the tuning tool for the top core. Use the long, thin end (which is inserted through the top core) for the bottom core.

It should not be necessary to turn the cores of transformers T201 and T103 more than two turns.

- () Adjust transformer T201 for maximum volume.
- () Adjust the top and bottom slugs of transformer T102 for a maximum volume or S-Meter indication.
- () Adjust the slug of transformer T103 for a maximum S-Meter indication.

- () Repeat the adjustments of transformers T201, T102, and T103 for a maximum S-Meter indication.

The driver grid and driver plate coils will be adjusted in the following steps. The coil locations are marked on the shield cover at the bottom of the chassis. These coils must be adjusted in the proper sequence as follows:

- () Adjust driver grid coil 3.5 and driver plate coil 3.5 for a maximum S-Meter indication. The S-Meter will move slowly during the adjustment of these two coils.
- () Change the setting of the front panel controls as follows:
DRIVER PRESELECTOR - 29.2 position.
See the inset drawing on Figure 1-2 (fold-out from Page 107).
BAND - 29.0
MAIN TUNING dial (LMO) - 29.2 MHz
- () Turn the MAIN TUNING dial back and forth around 29.2 MHz to get the loudest signal. Check for the calibrate signal by turning the DRIVER PRESELECTOR to see if there is a variation in volume. Return the DRIVER PRESELECTOR to the 29.2 position.
- () Adjust driver grid coil 29 and driver plate coil 29 for a maximum S-Meter indication.
- () Change the setting of the front panel controls as follows:
DRIVER PRESELECTOR - 21.2 position.
See the inset drawing on Figure 1-2.
BAND - 21.0
MAIN TUNING dial - 21.2 MHz.
- () Turn the MAIN TUNING dial back and forth around 21.2 MHz for the loudest signal. Check for the calibrate signal by turning the FUNCTION switch to VOX and back to CAL again.
- () Adjust driver grid coil 21 and driver plate coil 21 for a maximum S-Meter indication.
- () Turn the BAND switch to 14.0, the MAIN TUNING dial to 14.2 MHz, and the DRIVER PRESELECTOR to the 14.2 position.

- () Tune the MAIN TUNING dial for the loudest signal and check for the calibrate signal.
- () Adjust driver grid coil 14 and driver plate coil 14 for a maximum S-Meter indication.
- () Set the BAND switch at 7.0, the Main tuning dial at 7.2 MHz, and the DRIVER-PRE-SELECTOR to the 7.2 position.
- () Tune the MAIN TUNING dial for the loudest signal.
- () Adjust driver grid coil 7 and driver plate coil 7 for a maximum S-Meter indicator.
- () Turn the FUNCTION switch to PTT.

Proper receiver operation will be indicated by calibrator signals of S9 +20 dB at 3700 kHz and decreasing to S6 at 29.2 MHz.

TRANSMITTER ALIGNMENT

See the "Reading The Meter" section on Page 116 before making any more adjustments.

NOTE: The coil cover must be in place for transmitter operation.

- () Connect a push-to-talk microphone to the MIC connector on the front panel. Refer to Microphone Connection on Page 109.
- () If an oscilloscope is available, connect the oscilloscope between the RF OUT jack and the dummy load. Be sure the dummy load is capable of 100 watts dissipation.
- () Set the NEUTRALIZING CAPACITOR (on the RF cage) at the 1/2 meshed position. The slot in the shaft should be vertical.
- () Set the front panel controls as follows:
 DRIVER PRESELECTOR - 12 o'clock position.
 MIC/CW LEVEL - fully counterclockwise.
 FINAL (round knob) - to 80.
 FINAL (lever knob) - over the 50 Ω marking.
 MODE - LSB.
 BAND - 3.5.
 MAIN TUNING dial - 3.7 MHz.
 FUNCTION - PTT.
 FILTER - SSB.

FREQ CONTROL - LOCKED NORMAL.
 METER - PLATE.

- () Press the PTT microphone button and turn the BIAS ADJUST control in the Transceiver for a plate current reading of 50 mA. If the meter reads more than 100 mA, do not press the microphone button more than a few seconds at one time, until the plate current has been properly adjusted.
- () If an oscilloscope is not used, preset the RELATIVE POWER control to the center of its range and turn the METER switch to REL PWR.
- () With the MODE switch set at the TUNE position, slowly turn the MIC/CW LEVEL control in a clockwise direction until there is an indication of RF output on the meter or oscilloscope.
- () Turn the MIC/CW LEVEL control for a low level of RF output, then adjust the DRIVER PRESELECTOR control for maximum RF output.
- () Adjust the FINAL tune (round knob) control for maximum RF output.
- () Turn the MIC/CW LEVEL control counterclockwise to obtain approximately 1/4 maximum output.
- () Adjust transformer T1 for maximum RF output. It should not be necessary to adjust this transformer more than one complete turn.
- () Turn the MIC/CW LEVEL control and DRIVER PRESELECTOR control to obtain maximum RF output on the meter or oscilloscope. Then turn the METER switch to GRID (grid current). The meter should have some up-scale indication, and may indicate greater than full scale.
- () Turn the METER switch to the PLATE position.
- () Adjust the FINAL tune control for minimum plate current. Turn the METER switch to REL PWR or observe the output on an oscilloscope. Adjust the FINAL tune control for maximum meter indication and note the position of the FINAL tune control. (If necessary, readjust the RELATIVE POWER control so the meter does not indicate beyond full scale.) If maximum relative

power and minimum plate current do not occur at the same point of tuning, turn the neutralizing capacitor a small amount. Check the position of the FINAL tune control at minimum plate current and also at the maximum relative power indication. The neutralizing capacitor should be adjusted a small amount at a time until minimum plate current and maximum relative power occur at the same point of tuning the FINAL tune control.

- () Turn the MIC/CW LEVEL control fully counterclockwise.
- () Turn the MODE switch to LSB, push the PTT switch on the microphone, then adjust the CARRIER NULL control for minimum RF output. NOTE: Readjust the RELATIVE POWER control for more sensitivity if the panel meter is used to indicate relative power.
- () Adjust the CARRIER NULL capacitor for minimum RF output.
- () If necessary, repeat the adjustments of the CARRIER NULL control, and the CARRIER NULL capacitor until the RF output or null reading is about the same on both the LSB and USB positions of the MODE switch. (The output should null down to a quarter of a volt or less, if an RF voltmeter is available.)

NOTE: If the null capacitor tends to null when the rotor is completely meshed toward the LMO, remove the 12 pF mica capacitor at 18 on the foil side of the modulator circuit board. If the null capacitor tends to null when the rotor is completely meshed away from the LMO, remove the 12 pF capacitor and install the remaining 24 pF capacitor at 18 on the foil side of the modulator circuit board.

CAUTION: The 6.8 MHz trap coil is sealed, and should not be turned.

Perform the following steps for each position of the BAND switch beginning at 3.5.

1. Advance the MIC/CW LEVEL and tune the FINAL and DRIVER PRESELECTOR for maximum output.
2. Turn the METER switch to GRID and adjust the MIC/CW LEVEL control for a slight grid current reading so a peak can be seen when you make the adjustment in the next step.
3. Locate the heterodyne oscillator coil for the band in use, and adjust it for maximum grid current. This will be a slight adjustment.

4. Turn the MODE switch to LSB.

5. Turn the BAND switch to the next position.

- () Set the BAND switch at 21.0 and turn the MAIN TUNING dial to read 21.2 MHz.
- () Position the free end of the driver neutralizing wire into hole W in the RF-driver circuit board as shown in Figure 1-1 (fold-out from Page 88).
- () Adjust the DRIVER PRESELECTOR control for maximum RF output; then turn the control back and forth to see if this produces a smooth peaking in RF output.
- () If the turning of the DRIVER PRESELECTOR control causes ragged changes in the RF output, readjust the position of, or bend, the driver neutralizing wire to produce a smooth peaking in RF output.
- () Check the final neutralizing again at 14.2 MHz as in the last step on Page 103. This provides adequate neutralization for all bands.
- () Rezero the S-Meter while receiving, with the BAND switch at 29.5. Then check to be sure the meter reads zero in each Band switch position. If the S-Meter does not read zero on any band, readjust the heterodyne oscillator coil for that band, as directed in previous steps.

CRYSTAL CALIBRATOR ALIGNMENT

In the following steps, the 100 kHz crystal calibrator signal is adjusted by "zero beating" it against the accurate signal from WWV on another receiver, or against the signal from a standard broadcast station that is on a multiple of 100 kHz.

Zero beat will occur when a harmonic of the 100 kHz crystal calibrator signal corresponds to the frequency of the station tuned in on the external receiver. As zero beat is approached, a tone will be heard that decreases in frequency until it stops completely at the zero beat point; then the tone begins to increase again.

If the external receiver has an S-Meter, accurate alignment can be achieved by observing the S-Meter as zero beat is approached. When you tune close to zero beat, the S-Meter will start to pulsate. The closer you approach zero beat, the slower the pulsations will become. At zero beat the pulsations will stop.

IMPORTANT: For greatest accuracy, be sure to adjust the crystal calibrator as close to zero beat as possible. A 20 Hz error at the 100 kHz calibrator frequency, for example, would cause a 740 Hz error at 3.7 MHz (where the 37th harmonic of 100 kHz would be used for dial calibration purposes; $100 \text{ kHz} \times 37 = 3.7 \text{ MHz}$; $20 \text{ Hz} \times 37 = 740 \text{ Hz}$).

() Lay the antenna wire near crystal Y4 and tube V19 on the bandpass circuit board to pick up the 100 kHz oscillator signal.

() Set the Transceiver controls as follows:

FUNCTION switch - CAL.

AF GAIN control - fully counterclockwise.

MODE switch - CW, LSB, or USB.

() Tune the external receiver to WWV; or a standard broadcast station broadcasting at a frequency which is a multiple of 100 kHz.

() Carefully adjust the CAL XTAL trimmer capacitor (on the band pass circuit board) for a "zero beat" in the external receiver. When WWV is tuned in, the period when no tone modulation is present allows the zero beat to be more easily heard.

() Switch the Transceiver FUNCTION switch between VOX and CAL to be sure the external receiver S-Meter stays steady, thus insuring a true zero beat.

() Remove the external receiver antenna wire from the Transceiver.

NOTE: To make sure it is heard on each band, a high content of harmonic energy is needed in the 100 kHz calibrate signal. Because of this, some spurious signals may also appear when tuning across some segments of the bands. The desired 100 kHz calibrate signals are easily identified by their greater signal strength. Also, the proper harmonics may be peaked by the DRIVER PRESELECTOR.

LSB ADJUST

() Adjust the MAIN TUNING dial to 3.7 MHz (BAND switch to 3.5, the upper dial at 2, and the circular dial to 0).

() Set the FUNCTION switch to CAL.

() Turn the MODE switch to USB.

() Carefully zero beat the calibrator signal (using the MAIN TUNING dial) and peak the DRIVER PRESELECTOR control.

() Set the MODE switch to LSB. Be careful not to touch the MAIN TUNING dial. Note that the calibrator signal may or may not be exactly at zero beat in the LSB position.

() Turn the LSB ADJUST screw on the LMO for an exact zero beat in the LSB mode. See Figure 1-1 (fold-out from Page 88).

() Recheck the zero beat in the USB mode to be certain of the adjustment. Repeat the procedure if necessary.

DIAL CALIBRATION

() Zero beat the MAIN TUNING dial at 3.7 MHz.

() Check for the calibrate signal and set the Zero Set dial. If the hairline is not close to the window center, proceed with the following steps.

() Remove the knob from the MAIN TUNING shaft without disturbing the zero beat setting.

() Place a screwdriver through the hole in the dial escutcheon (directly above the main tuning shaft) and into the LMO dial drive shaft.

() Hold the LMO dial drive shaft on zero beat and loosen the setscrew in the circular dial. Turn the circular dial until the 0 is directly centered behind the line on the zero set dial. Now retighten the setscrew in the circular dial. Wrap tape around the allen wrench so you do not short circuit the pilot lamp socket with the allen wrench.

() Make sure the circular dial turns freely and the nylon spiral follower is properly engaged in the spiral groove before proceeding.

() Replace the knob on the MAIN TUNING shaft.

This completes the alignment of your Transceiver.

SPECIAL CRYSTAL CONSIDERATIONS

CRYSTAL CONTROL FOR MARS OR NET OPERATION

With the **FREQ CONTROL** switch of the Transceiver in the **UNLOCKED AUX** position, the transmitter operates at a fixed frequency that is determined by crystal Y5 in the crystal oscillator circuit of tube V5B. The receiver is still tuned by the LMO.

By placing the **FREQ CONTROL** switch in the **LOCKED AUX** position, both the transmitter and receiver frequencies are determined by crystal Y5.

IMPORTANT: Because of the steep-sided characteristics of Bandpass filter T202, operation of the Transceiver using a crystal at Y5 will be limited to approximately 25 kHz outside of each band. Also, since the **DRIVER PRESELECTOR** tunes the same circuit for both transmit and receive, the frequency spread between the transmit and receive frequencies is limited to about 20 kHz at 3.5 MHz, 40 kHz at 7 MHz, etc.

Select the crystal frequency for Y5 for the sideband to be used, or for CW operation. The examples below are for one of the MARS channels located at 7.305 MHz.

For USB and compatible USB-CW operation:

$$f_{x(USB)} = f_h - f_m - 3.3964$$

For LSB operation:

$$f_{x(LSB)} = f_h - f_m - 3.3936$$

For CW Net operation:

$$f_{x(CW)} = f_h - f_n - 3.3954$$

Definition of terms:

f_x = Crystal frequency in MHz, for crystal Y5.

f_h = heterodyne crystal frequency, different for each band:

<u>BAND</u>	<u>f_h *</u>
3.5	12.3950
7.0	15.8950
14.0	22.8950
21.0	29.8950
28.0	36.8950
28.5	37.3950
29.0	37.8950
29.5	38.3950

f_m = carrier frequency of desired SSB operation, further specified by LSB or USB designations. This is the operating frequency for SSB.

***NOTE:** Because of the manufacturing tolerances of the heterodyne crystals, these frequencies may be in error by as much as 1500 Hz. For critical applications it will be advisable to measure the heterodyne crystal frequencies exactly to obtain correct values of f_h for the above formulae.

To measure the heterodyne oscillator frequency, connect a frequency counter or a frequency meter through a small capacitor to pin 7 of V11. Leave the transceiver in the Receive mode with the **FREQ CONTROL** switch in the **LOCKED AUX** position, **RF GAIN** fully counterclockwise, in **PTT** and at **LSB**.

f_n = Exact transmitter frequency for CW Nets. Use this where CW only is used on a specific frequency. This operation is not compatible with USB operation, as the receiving station would have to retune his receiver 1 kHz lower to receive SSB, and this would be impossible if he were crystal controlled.

Compatible USB-CW operation is used in some MARS Nets. In this service, a channel is specified which is wide enough for only one sideband. The carrier frequency is specified at the lower edge of the channel, and CW transmission is 1 kHz higher than the carrier frequency. This 1 kHz offset then produces a 1 kHz beat note in the receivers set to USB or CW without any tuning. Either USB or CW can then be transmitted or received.

When using auxiliary crystal control, switching modes will cause the transmitting frequency to change, except for compatible USB-CW operation. Therefore, care must be taken to avoid out-of-band operation by inadvertently switching to the wrong mode.

Example: MARS SSB on USB at 7.305 MHz.

$$f_{h(7.0)} = 15.8950$$

$$f_{m(USB)} = \frac{-7.3050}{8.5900}$$

$$8.5900$$

$$\frac{-3.3964}{}$$

$$f_{x(USB)} = 5.1936 \text{ MHz}$$

Caution: Always be sure to use the correct heterodyne crystal frequency.

When purchasing crystals for Y5, specify the frequency and the following characteristics:

Operation Mode	Fundamental.
Tolerance01 %.
Holder	HC-6/U.
Pin Diameter050".
Pin Spacing486.
Load Capacity (C_L)	32 pF.
Internal Capacity (C_0)	7 pF maximum.
Series Resistance (R_s)	25 Ω maximum.
Drive Level	10 milliwatts.

The trimmer capacitor next to Y5 (AUX TRIM) can be adjusted for an exact MARS or Net frequency.

HETERODYNE OSCILLATOR

The heterodyne oscillator crystals that are supplied with the Transceiver provide coverage from 3.5 to 4.0 MHz, 7.0 to 7.3 MHz, 14.0 to 14.5 MHz, 21.0 to 21.5 MHz, and 28.0 to 30.0 MHz. Since the driver grid and driver plate coils must be sequence-tuned, because of their series-parallel arrangement, other heterodyne crystals for out-of-band operation could introduce a wide variety of possible tuning conditions. Therefore, the use of crystals of frequencies other than those supplied is not recommended.

MICROPHONE CONNECTION

Refer to Figure 1-7 for the following steps.

NOTE: A high-impedance microphone equipped with a push-to-talk switch should be used with the Transceiver so either the PTT or VOX methods may be used to turn on the Transmitter. A two-pin microphone connector (Amphenol 80MC2M) is furnished for this purpose. It should be connected to the microphone cable as directed in the following steps.

- () Determine the desired length of your microphone cable, and cut off any excess.
- () Perform the numbered steps in Figure 1-7.

IDENTIFICATION LABEL

NOTE: The blue and white identification label shows the Model Number and Production Series Number of your kit. Refer to these numbers in any communications with the Heath Company; this assures you that you will receive the most complete and up-to-date information in return.

- () Install the identification label in the following manner:
 1. Select a location for the label where it can easily be seen when needed, but will not show when the unit is in operation. This location might be on the LMO chassis. See Figure 1-6.
 2. Carefully peel away the backing paper. Then press the label into position.
- () Fill out the registration card and mail it to the Heath Company.

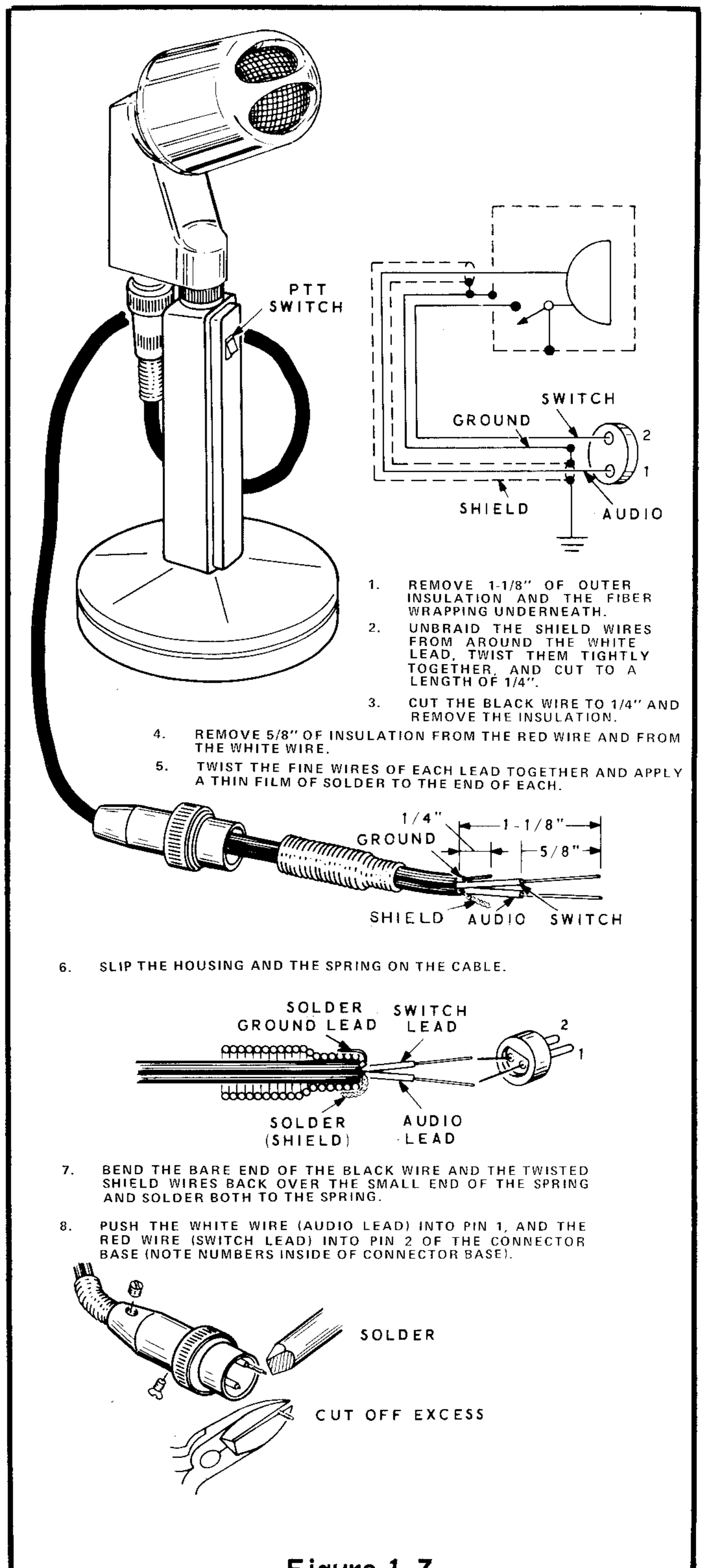

Figure 1-7

INSTALLATION

Because of the heat generated by the tubes of the Transceiver, it should be placed where adequate air circulation is present. Do not place other equipment, papers, or other objects under or on top of the Transceiver that would cut off air circulation through the unit.

FIXED STATION INSTALLATION

Figure 1-8 (Page 111) shows a basic fixed station hookup. Figure 1-9 (fold-out from Page 108) shows various accessories that may be used with the Transceiver. These same accessories may also be used with a linear amplifier; however, linear amplifiers are shown separately in Figure 1-11 (fold-out from Page 121) for clarity.

Cables can be prepared following the instructions in Figure 1-10. Make the cables to the lengths required for your installation.

Linear Amplifier Considerations

HEATH AMPLIFIERS

Figure 1-11 shows the installation of the Transceiver with Heath amplifiers. Both provide ALC voltage for the exciter and have internal antenna switching.

ANTENNA RELAY CONNECTIONS

Many amplifiers have an internal transmit-receive relay which is actuated by grounding the relay coil circuit. Heath amplifiers are of this type, and Heath amateur transmitters and transceivers have relay contacts available to operate the

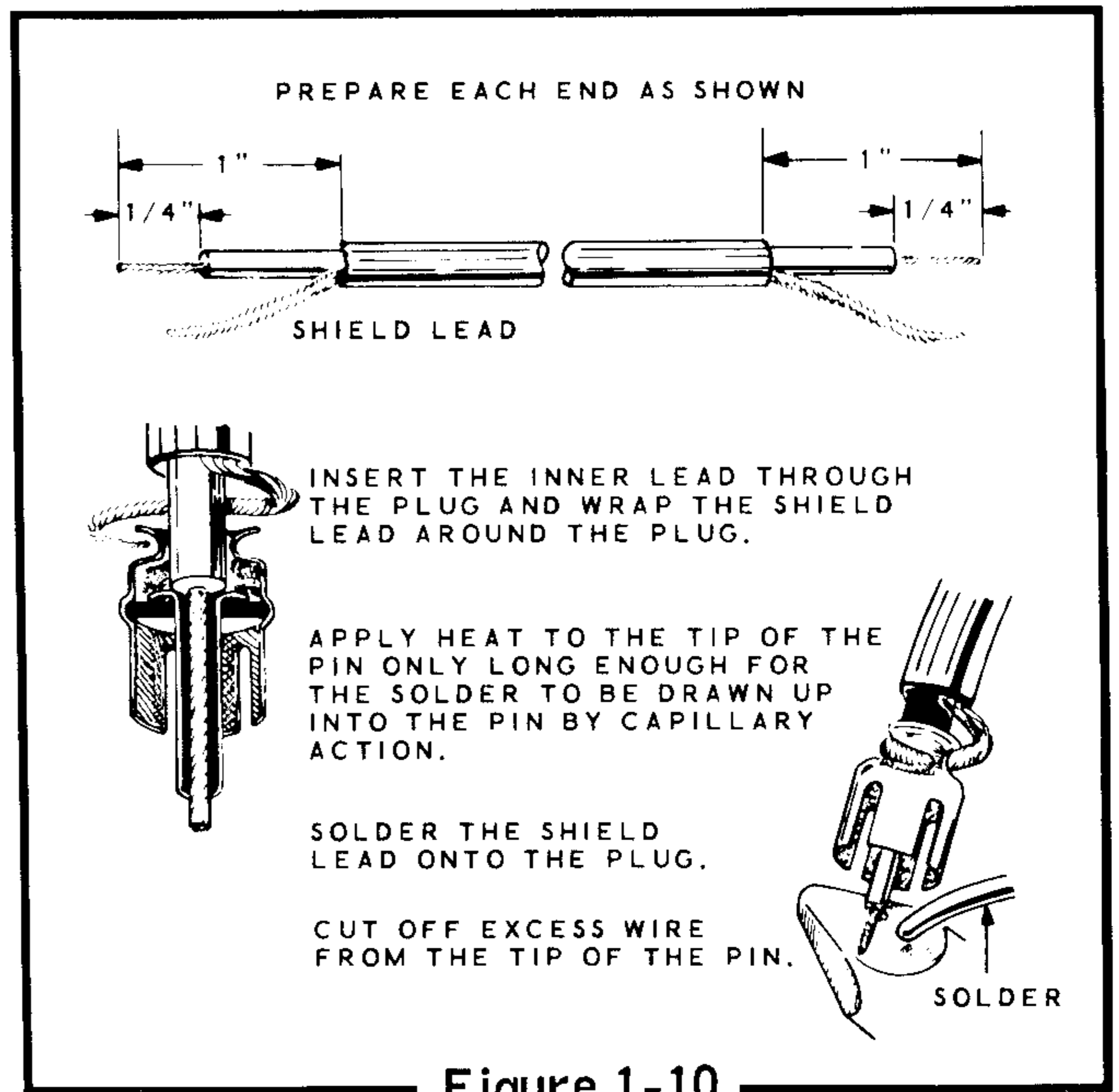

Figure 1-10

relay. This grounding connection may be made by a shielded cable (or other two-conductor wire) connected to the power cable socket as shown in the Power Supply Connections section of this Manual (see Figure 1-5).

Another, and possibly more convenient, method is to install a jumper wire from pin 11 of the power plug to the spare phono socket, both on the chassis rear apron. To install the jumper, strip 1/2" of insulation from a hookup wire, melt the solder in pin 11 of the power plug, and insert the bare end of the added wire into the pin from the back side of the plug.

Then solder the free end of the wire to lug 1 of phono socket AD (illustrated in Pictorial 8-5). The relay contacts are rated at 3 amperes maximum at 30 V DC or 120 V AC.

OTHER LINEAR AMPLIFIERS

Information regarding antenna switching, cutoff bias, and ALC should be obtained from the Linear Amplifier Instruction Manual.

A spare set of SPST relay contacts is available at the PWR plug of the Transceiver (pins 5 and 11). These contacts can be used to switch an external antenna relay by grounding pin 11 in the transmit mode. The current rating of these contacts is 3 amperes maximum at 30 V DC or at 120 V AC.

Pin 5 is grounded. Do not connect it to 120 V AC without an isolation transformer.

If the linear amplifier being used has internal antenna switching capabilities, an external antenna relay is not necessary. The spare relay contacts in the Transceiver can now be used to switch either the cutoff bias or the internal antenna relay of the linear amplifier.

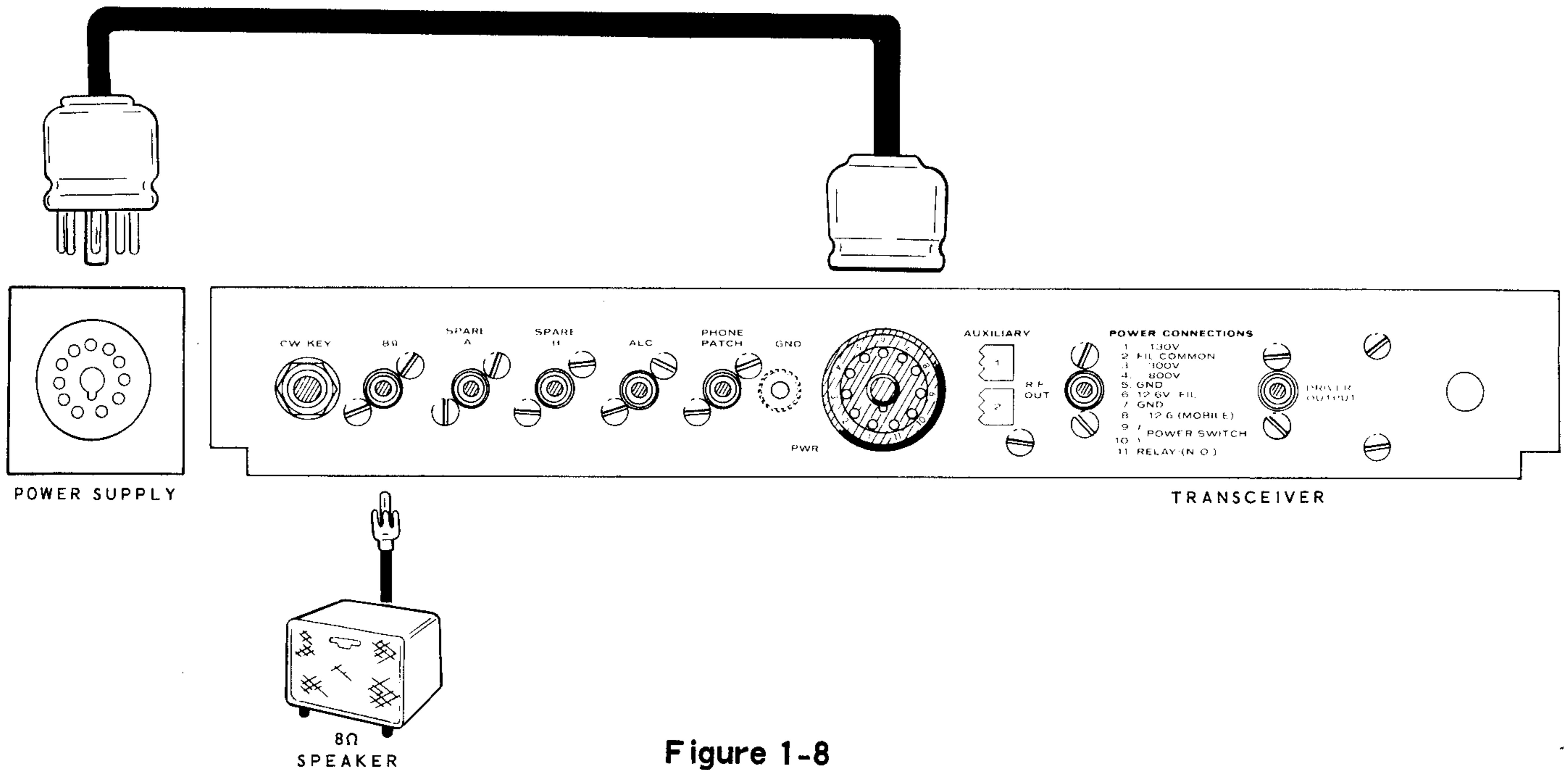
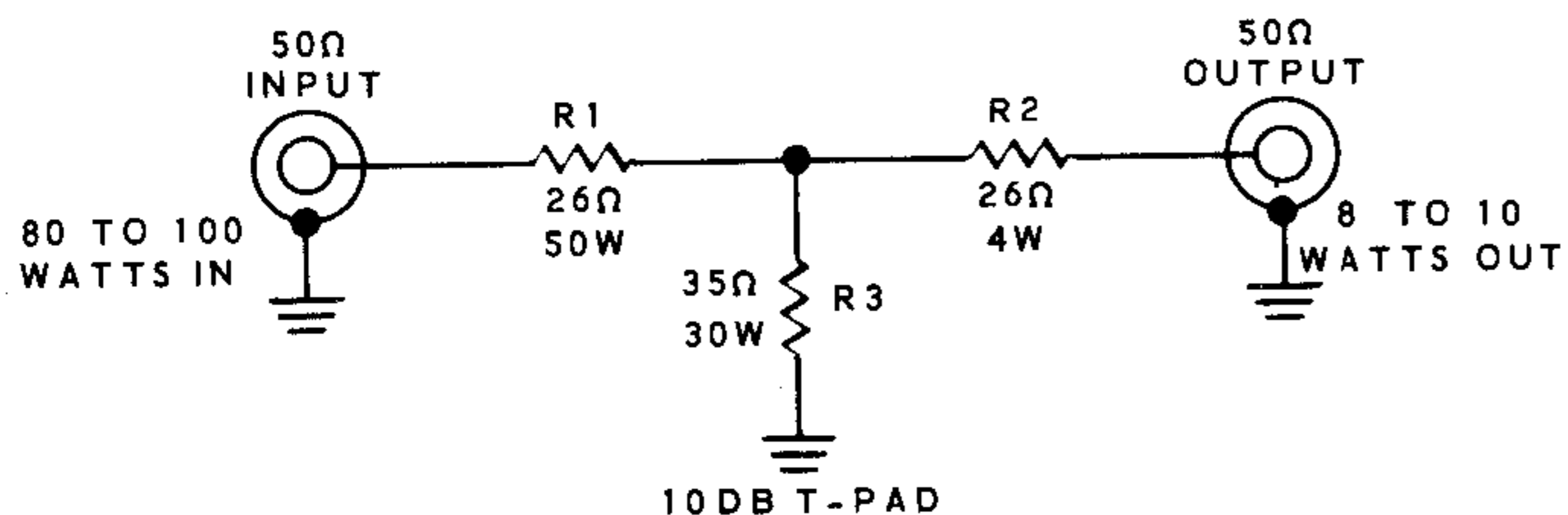

Figure 1-8



T-Pad

If the output power of the Transceiver is too high for the drive requirements of the linear amplifier, a swamping T-pad must be used between the two units. Such a pad is shown in the above Figure. This pad will provide 10 dB attenuation with a terminal impedance of 50 ohms. This will allow adequate driving power for a linear amplifier that requires 10 watts input.

MOBILE INSTALLATION

A Mobile Mount (Heathkit Model SBA-100-1) is available for use with the Transceiver, and is recommended for Mobile operation. With this mount, the Transceiver can be quickly and easily installed or removed so it can be used for mobile and fixed station operation.

Be sure the voltage regulator of the automobile is set to not exceed 14.5 volts.

Mobile Antennas

Mount the antenna according to the manufacturer's instructions. Be sure to make a good ground connection between the shield of the coaxial cable and the car body at the antenna base.

Mobile antennas present loading situations which must be carefully handled for each band. Because whip antennas must be kept short for mobile use, they represent only a fraction of a wavelength on the lower frequency bands. Thus, their radiation resistance is extremely low and their reactance is capacitive. Therefore, loading coils must be used and the losses kept low to insure a minimum loss of radiated power in the form of heat in the loss resistances.

A good quality antenna will have low resistance losses, and with a high "Q" loading coil, its bandwidth on 75 meters could be less than the IF bandwidth of many receivers used for AM reception. A typical loading coil with a "Q" of 300 would have a bandwidth of 13 kHz to the half-power points at 3.9 MHz.

Because of this sharp tuning, deviation from the center frequency of the antenna will quickly introduce enough reactance to present an impossible loading situation to the transmitter. The antenna should be carefully adjusted for a low SWR before placing the transmitter in operation.

The following is a list of antenna considerations for each band of the Transceiver.

3.5-4 MHz

This band presents the greatest problem. The normal tuning range of a good antenna on this band is about 10 kHz on each side of the antenna's resonant frequency.

Actual measured resistance at the base of an antenna at these frequencies is 15 to 20 ohms; this represents an SWR of nearly 3 to 1. In order to get proper matching to the 50 ohm line, a 1000 pF mica capacitor should be connected between the inner conductor and shield of the coaxial line at the base of the antenna. Some antennas may require a different value, somewhere between 300 and 1500 pF.



The antenna tuning must be checked after the capacitor is installed. This capacitor is part of an L network that is used to get a 50 ohm match. The inductive portion of this network is formed by a portion of the loading coil.

7-7.3 MHz

This band ordinarily does not need a correcting network, and has a useful bandwidth of about 50 kHz.

14 MHz

No network needed. Bandwidth is approximately 100 kHz.

21 MHz

No network needed. Bandwidth is about 150 kHz.

28 MHz

The antenna for this band is normally cut for 1/4 wavelength, with no loading coil required. The bandwidth is about 200 kHz.

TYPICAL TUNING PROCEDURE

The following is a typical tuning procedure.

A whip antenna that is properly tuned on 75 meters will have a high peak of receiver activity for about 25 kHz around the antenna's resonant frequency. Turn on the receiver and tune through the band to find the peak of receiver activity for the present setting of your antenna. Then adjust the length of the whip in 1/4 inch increments and retune the receiver until the peak of receiver activity is centered around the frequency at which you normally operate. The antenna can then be tuned as described in the following steps. The receiver peaking may not be noticeable on bands other than 75 meters.

() 1. Connect an SWR meter in series with the lead to your antenna.

() 2. Set the SWR meter to the "forward" position.

() 3. Turn the Meter switch on your Transceiver to PLATE. If the meter needle does not point to 50 mA when the PTT button is depressed, perform the Bias Setting steps in the first step in the right-hand column on Page 103.

() 4. Turn the MODE switch to TUNE.

() 5. Adjust the MIC GAIN control for a full-scale meter indication on the SWR bridge. Peak the Final TUNE and DRIVER PRESELECTOR controls.

() 6. Switch the SWR meter to the "reverse" position. Note the SWR reading.

() 7. Switch the SWR meter to the "forward" position. Then set the transmitter to higher and lower frequencies, and repeat steps 5 and 6 at each frequency, until you find the minimum SWR.

() 8. Set the transmitter to the desired operating frequency. Then adjust the length of the antenna as follows:

A. If the point of the lowest SWR is lower than the desired operating frequency, shorten the antenna as described below.

B. If the point of lowest SWR is higher than the desired operating frequency, lengthen the antenna as described below.

C. Change the antenna length in 1/4" increments and repeat steps 2, 5, and 6 at each new length until the minimum SWR is obtained. The SWR should be about 1.2 or less at the desired frequency. NOTE: It may be necessary to add a capacitor at the base of the antenna, as described previously, if you cannot get the SWR down to about 1.2.

Noise Suppression

To obtain good noise suppression, you must suppress electrical interference at its source, so it does not reach the input of the receiver. Once it has been radiated, noise cannot be suppressed by bypassing, etc.

It is difficult to determine the source of various types of noise, particularly when several items are contributing to the noise. Follow the procedure outlined below to isolate and identify the various items that may be producing the major noise interference.

In most cases, one source of interference will mask others. Consequently, it will be necessary to suppress the strongest item first, and then continue with the other steps. Figure 1-12 (fold-out from Page 108) shows a typical ignition system and the suggested placement of noise suppression components.

1. Position the vehicle in an area that is free from other man-made electrical interference such as power lines, manufacturing processes, and particularly other automobiles.
2. With the Transceiver on, run the automobile at medium speed. Then let up on the gas, and turn the ignition switch off and to the accessory position. Allow the vehicle to coast in neutral. If all noise stops, the major source of interference is from the ignition system. This may not be possible on cars with automatic transmissions or power steering.

3. If the noise has a "whine" characteristic and changes in pitch with varying engine speed and is still present with the ignition off, then the generator is the major source of interference.
4. A distinct but irregular clicking noise, or "hash" as it is sometimes called, that disappears with the engine idling, indicates the voltage regulator is at fault.
5. A steady popping noise that continues with the ignition off indicates wheel or tire static interference. This is more pronounced on smooth roads.
6. The same type of interference as in step 5, but more irregular when on bumpy roads, particularly at slow speeds, indicates body static.

Refer to the Troubleshooting Chart on Page 115 and Figure 1-12 (fold-out from Page 108), to help determine how to suppress most noise interference. Naturally, not all vehicles will require suppression to the extent shown in Figure 1-12, but some stubborn cases may require all the suppression components shown, plus shielding of the ignition system.

Bonding of various parts of the automobile, starting from the hood and continuing to the trunk, even including bonding of the transmission line every few feet from the antenna may be necessary.



NOISE SUPPRESSION TROUBLESHOOTING CHART

TYPE OF NOISE	POSSIBLE CAUSE	RECOMMENDED REMEDY
Loud popping increasing to buzz with increased engine speed.	Ignition system.	<ol style="list-style-type: none"> 1. Replace plugs with resistor type. (Most recommended.) 2. Loose crimped connections should be cleaned and soldered. 3. Place resistors in distributor system.
Whine - varies with engine speed.	Generator.	<ol style="list-style-type: none"> 1. 0.1 μF coaxial type capacitor in series with the armature (A lead). 2. Clean commutator. 3. Replace brushes. 4. Ground generator shaft. 5. Parallel trap (#10 wire-coil and suitable capacitor) in series with armature lead, tuned to operating frequency.
Distinct but irregular clicking noise.	Voltage regulator.	<ol style="list-style-type: none"> 1. 0.1 μF coaxial type capacitor in series with the battery (B) and armature (A) leads. 2. A series combination of a .002 μF mica capacitor and a 4 Ω carbon resistor to ground from the field (F) terminal. All components should be mounted as shown in diagram, close to voltage regulator.
Same as above.	Energy transfer to primary system.	<ol style="list-style-type: none"> 1. Bypass at the following points: coaxial bypass in lead to coil from ignition switch (0.1 μF). Battery lead to ammeter (.5 μF); to gas gauge (0.5 μF); to oil signal switch (0.5 μF); head and tail light leads (.5 μF); accessory wiring from engine compartment (.5 μF).
Loud popping noise that changes from one type road to another. Most pronounced on concrete.	Wheel static.	<ol style="list-style-type: none"> 1. Installation of front wheel static collectors (available from most automotive distributors). These should be checked every 5000 miles for excessive wear.
Same as above.	Tire static.	<ol style="list-style-type: none"> 1. Injection of anti-static powder into tire through valve stem.
Irregular popping noise when on bumpy roads, particularly at slow speeds.	Body static.	<ol style="list-style-type: none"> 1. Tighten all loose screws. 2. Use heavy flexible braid and bond the engine to the frame and fire wall. Bond the control rods, speedometer cable, exhaust pipes, etc., to the frame.

If an extensive amount of suppression is required, the engine should be retimed and tuned up at a reputable garage.

OPERATION

NOTE: YOU MUST HAVE AN AMATEUR RADIO OPERATOR AND A STATION LICENSE BEFORE PLACING THE TRANSMITTER SECTION OF THE TRANSCEIVER ON THE AIR. INFORMATION ABOUT LICENSING AND AMATEUR FREQUENCY ALLOCATIONS IS AVAILABLE FROM PUBLICATIONS OF THE FEDERAL COMMUNICATIONS COMMISSION OR THE AMERICAN RADIO RELAY LEAGUE.

Operation of the Transceiver has been simplified as much as possible to permit rapid adjustment by the operator. Once the initial settings have been made, it should not be necessary to readjust most of the controls. Read the following information carefully. Good operating techniques will provide good clean signals and long trouble-free life of the Transceiver.

CAUTION: Be sure a 50 to 75 Ω nonreactive load is connected to the ANT RF OUT jack before operating the Transceiver. This load can be an antenna, a dummy load, or a properly adjusted linear amplifier. (See the Installation section of the Manual on Page 110.)

RTTY OPERATION

Read the following information before you attempt to use the internal FSK (Frequency Shift Keying) circuitry in the LMO for RTTY (Radio Teletype) operation.

CAUTION: To avoid overheating of the power amplifier stage and the power supply:

- A. A fan must be provided.
- B. The power amplifier screen current must be lowered to keep the plate input to 150 watts or less. This can be done by using a resistor in place of the jumper on the 9-terminal cable socket.

Note for carrier crystal frequencies that:

- A. The crystals supplied with the Transceiver are not of the proper frequencies to provide normal 2125 to 2975 audio tones in the LSB mode.
- B. The crystals supplied with the Transceiver will not transmit and receive on the same frequency for RTTY.
- C. Crystals are not available from the Heath Company.

READING THE METER

Refer to Figure 1-13 and study the meter scale. Note how it reads for various positions of the Meter switch. Observe that the meter has two main scales and an ALC area.

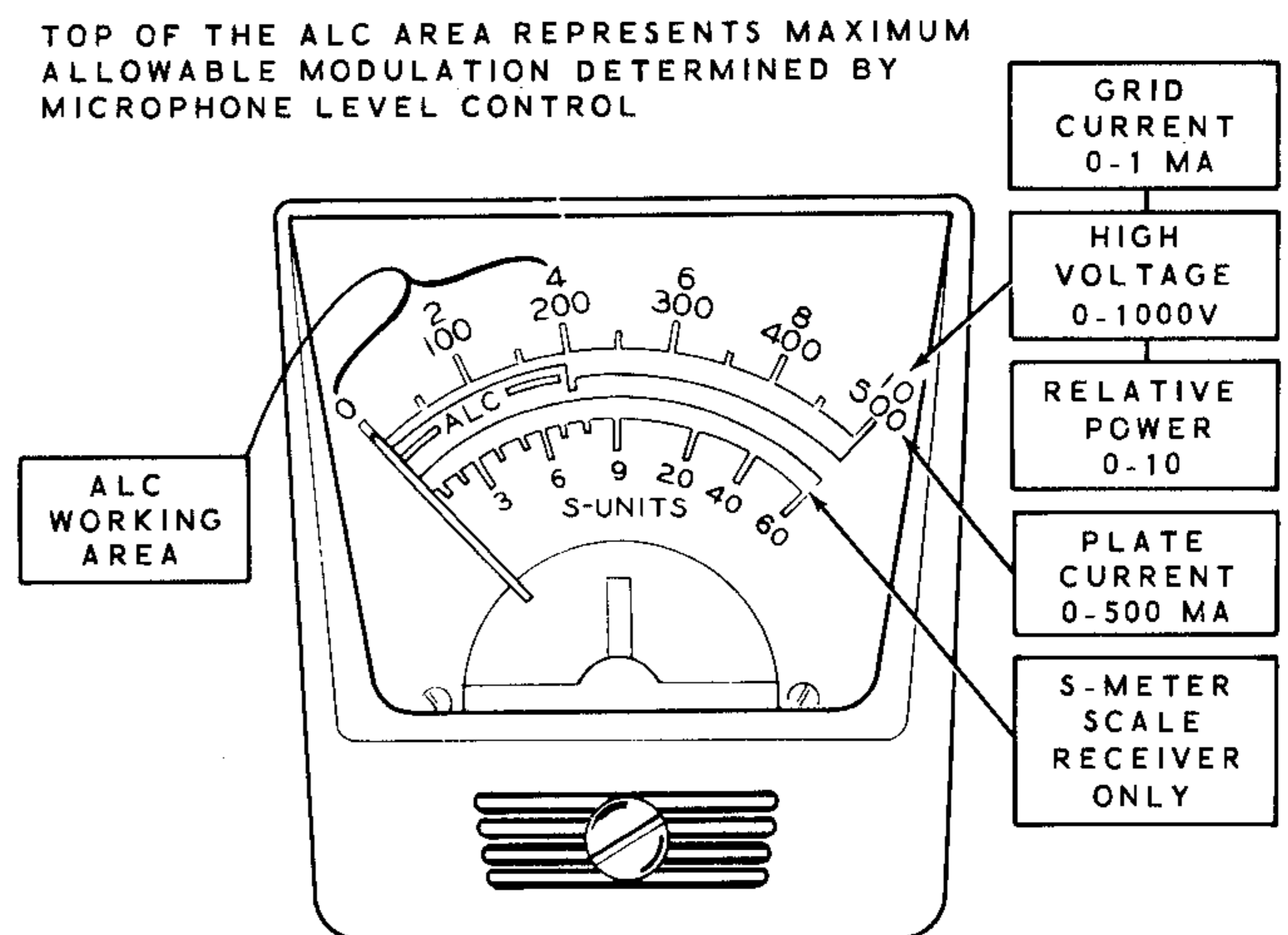

Figure 1-13

For receiver operation, the meter operates as an S-Meter and reads from 0 to 60, with the METER switch in the ALC position.

For transmit operation, the scale numbered from 0 to 10 is read directly for relative power, 0 to 1 mA for grid current, and 0 to 1000 for high voltage indications. Read the 0 to 500 scale directly to read plate current in milliamperes.



RECEIVER SECTION

Connect an 8 Ω speaker to the 8 Ω SPEAKER jack, or plug a set of headphones into the PHONES jack.

1. Set the MODE switch to either LSB or USB.
2. Set the FREQ CONTROL switch to LOCKED NORMAL.
3. Turn the RF GAIN control to its fully clockwise position.

If an extremely strong station overloads the receiver front end, or if there are many weaker signals near the desired signal, leave the AF GAIN control set for comfortable listening; then adjust the receiver level with the RF GAIN control. This will keep the front end from overloading and masking the weaker signals.

The S-Meter will move with adjustment of the RF GAIN control, but will still read correctly with the RF GAIN set at less than maximum, if the received signal level is high enough to register on the S-Meter. For example: if the RF GAIN control is set for a no-signal meter reading of S-5, and the meter registers S-9 with a signal, then the received signal is S-9.

4. Set the FUNCTION switch to PTT and allow the Transceiver to warm up.
5. Adjust the AF GAIN control clockwise until some receiver noise is heard.

NOTE: The AF GAIN control adjusts the overall receiver (speaker and headphones) volume. When headphones are used, set the HEADPHONE VOL control to the same relative level as the speaker. Then regardless of whether a speaker or headphones are used, only the AF GAIN control need be changed for different volume levels.

6. The Transceiver is now ready to receive. Turn the BAND switch to select the desired 500 Hz band segment. The frequency of the tuned signal is determined by adding together the settings of the BAND switch, the upper dial, and the circular dial.

7. Peak the DRIVER PRESELECTOR for maximum signal.
8. Turn the FUNCTION switch to CAL. Rotate the Main Tuning dial (LMO) to the nearest 100 kHz point (0 on the circular dial).

Adjust the MAIN TUNING dial until the calibrate signal is at zero beat. (To be sure that the correct calibrate signal is being used, check the DRIVER PRESELECTOR tuning. If the signal strength varies, you are tuned to the correct calibrator signal.)

WARNING: Some portions of each band are for CW operation only. Do not operate the transmitter (with modulation) in the VOX or PTT modes if the receiver is tuned to these portions of the bands and the FREQ CONTROL switch is in the LOCKED NORMAL position, or the transmitted signal will be outside of the phone part of the band. (When the FREQ CONTROL switch is in the LOCKED NORMAL position, the transmitter and receiver operate on the same frequency.)

TRANSMITTER SECTION

Initial Tune Up

The first 10 steps of this procedure must be performed for all modes of operation.

1. Set the BAND switch and MAIN TUNING dial for the desired frequency.
2. Place the METER switch in the PLATE position.
3. Turn the MIC/CW LEVEL control fully counterclockwise.
4. Set the FREQ CONTROL switch to LOCKED NORMAL. If crystal control of the transmitter is desired, set the FREQ CONTROL switch to UNLOCKED AUX. (See the Special Crystal Considerations section on Page 106 of the Manual.)
5. With the RF load connected to the RF OUT jack, set the MODE switch to TUNE. The meter should read 50 mA.

CAUTION: For the following steps, do not leave the transmitter on at full output for extended periods of time or the final amplifier tubes and/or the power supply may be damaged.

6. Set the METER switch to REL PWR and adjust the FINAL loading control (lever knob) to 50. Be sure the FINAL tuning (round knob) indicates the band segment of the band in use.
7. Turn the MIC/CW LEVEL control clockwise to obtain an up-scale REL PWR indication on the meter. Then adjust the DRIVER PRESELECTOR, the FINAL tuning, and the FINAL loading controls for a maximum meter indication. Switching the meter to PLATE should show approximately 250 mA with the MIC/CW LEVEL control set for maximum output.

NOTE: Observe, while turning the MIC/CW LEVEL control clockwise, that the plate current and relative power readings reach a saturation point. Rotation of the control past this point will not increase the power output or the meter readings, but could result in distorted signals.

8. Return the MIC/CW LEVEL control to its full counterclockwise position.
9. Place the MODE switch in the position for the desired mode of operation: USB, LSB, or CW.

CAUTION: The Transceiver should be retuned if the frequency is changed by any great amount. Be sure to readjust the FINAL tuning and loading controls. It may also be necessary to repeak the DRIVER PRESELECTOR control.

This completes the Initial Tune Up. Before placing the Transceiver in operation, complete either the following CW or Single Sideband adjustments.

CW Operation

For CW operation the FUNCTION switch can be set to either the PTT or VOX positions. Even though CW operation is possible in the CALIBRATE position, it is not recommended because of possible spurious outputs.

NOTE: For 400 Hz CW selectivity, the Heath SBA-301-2 CW Crystal Filter must be installed.

Be sure steps 1 through 9 have been satisfactorily completed before proceeding with the following adjustments.

10. Place the MODE switch in the CW position.
11. Plug a key into the CW KEY jack.

The VOX SEN, ANTI-TRIP, and VOX DELAY controls are located on the control bracket under the cabinet cover.



12. While sending a series of "V's" adjust the VOX DELAY control so the relays stay energized between groups of characters. Clockwise rotation of this control will increase the holding time of the relays.

The final setting of the VOX DELAY control will be determined by the sending speed of the operator. The slower the sending speed, the higher the setting of this control. NOTE: Be sure the VOX DELAY control is adjusted so the relays do not open after each character is sent.

13. Hold the key down and adjust the CW TONE VOLUME control for a comfortable monitoring level.

NOTE: The frequency of the CW output signal is 1000 hertz higher than the dial reading. The received signal is actually in the USB position even though the MODE switch is set at CW. Consequently, cross-mode operation is possible between USB and CW without any resetting of the MAIN TUNING dial. For example, if two stations begin operation in the USB mode of operation and one operator changes to CW, the other station will hear a 1000 hertz note without retuning his receiver. Also, the station operating in the CW mode will receive the USB signal from the other station without

changing back to the USB position of the MODE switch. When operating in the LSB mode, if the operator changes to USB or CW, contact will be lost until the other station changes to either USB or CW.

14. The FILTER switch may be used in either the SSB or CW position (with the 400 Hz filter installed) for CW operation, depending upon the receiver selectivity desired. Transmission will not be affected.

Single Sideband Operation

Be sure steps 1 through 9 have been satisfactorily completed before proceeding with the following adjustments.

10. Set the MODE switch to either the USB or LSB position.
11. Set the FILTER switch to SSB.
12. Connect a microphone to the MIC connector.
13. Place the FUNCTION switch in the PTT position. (If your microphone does not have push-to-talk capabilities, make the VOX adjustments first, and then proceed with step 14.)

14. Set the METER switch to ALC.
15. Actuate the transmitter (PTT or VOX); and while speaking into the microphone, turn the MIC/CW LEVEL control clockwise until the peak deflections register at about S-6 on the meter. Do not allow the meter to deflect beyond the ALC area.

NOTE: With the METER switch in the GRID position, there will be very little meter indication during voice operation.

VOX ADJUSTMENTS

- () Turn the MIC/CW LEVEL control fully counterclockwise. Leave this control in this position for the following adjustments.

- () Set the FUNCTION switch to VOX.

NOTE: Close-talk into the microphone when using VOX operation to prevent background noise from tripping the Transceiver into transmit operation.

- () While speaking into the microphone, turn the VOX SENSitivity control to just beyond a setting that will energize the relays. Be sure this control is not set so high that it will allow background noise to trip the relays.

- () Tune the receiver to a fairly strong signal and adjust the AF GAIN control for a comfortable listening level.

- () Place the microphone where it will normally be used. Advance the ANTI-TRIP gain control to just beyond a setting that will keep the speaker signal from tripping the relays (through the microphone and VOX circuits). Be sure this control is not set so high that it completely disables the relay closing action.

- () While speaking into the microphone, turn the VOX DELAY control to a setting that will hold the relays energized during the slight pauses between words. This prevents the relays from tripping at the beginning and end of each word.

NOTE: There will be a slight interaction between the VOX SEN, ANTI-TRIP, and VOX DELAY controls. Consequently, it may be necessary to readjust these controls slightly to achieve the desired results.

The Transceiver is now ready for transmit operation in the SSB mode. Speaking into the microphone (VOX) or using the microphone push-to-talk switch (PTT) will change the Transceiver from receive to transmit operation. Remember, as long as the FREQ CONTROL switch is in the LOCKED NORMAL position, the receiver and transmitter are locked on the same frequency.

OPERATION WITH A LINEAR AMPLIFIER

Operation with a linear amplifier is similar to operation with an antenna at the output of the Transceiver, except that the linear amplifier input may have a different impedance. This will make it necessary to adjust the FINAL Tuning and Loading controls for maximum output (input to the linear amplifier). Figure 1-11 on Page 111 shows the proper connections between a linear amplifier and the Transceiver.

NOTE: The following adjustment should be made with the automobile engine running at about a 30 mph speed so the generator is charging.

Activate the transmitter with the push-to-talk button on the microphone, and adjust the bias control in the HP-13A Power Supply for a plate current reading of 50 mA. This will make it unnecessary to readjust the BIAS control of the Transceiver each time it is changed from mobile to fixed station use.

MOBILE OPERATION

If the Heathkit Model HP-13A Power Supply is to be used with the Transceiver in a mobile installation, and the BIAS control in the Transceiver has already been preset for fixed station operation, make the following adjustments.

- () Turn the MIC/CW LEVEL control fully counterclockwise.
- () Place the MODE switch in either the USB or LSB position.
- () Set the FUNCTION switch to PTT.
- () Place the METER switch in the PLATE position.

The VOX SEN, VOX DELAY, and ANTI-TRIP gain circuits will operate in mobile use, but because of the different power supplies, it may be necessary to readjust these controls. For VOX operation, leave clearance in the mobile installation so the Transceiver cover can be opened to make these adjustments.

Transmitter loading may be somewhat more critical on mobile antennas because of their sharper frequency characteristics. Consequently, the mobile antenna must be tuned as closely as possible to the desired operating frequency with the lowest possible SWR (standing wave ratio).

IN CASE OF DIFFICULTY

NOTE: In an extreme case where you are unable to resolve a difficulty, refer to the "Customer Service" information inside the rear cover of the Manual. Your Warranty is located inside the front cover of the Manual.

A review of the Operation and Installation sections of the Manual may indicate any conditions overlooked.

NOTE: At no time should the LMO be opened or the Warranty will be voided.

Refer to the Schematic Diagram (fold-out from Page 165) and to the Chassis Photos and X-Ray Views (Pages 156 to 161) for the location of parts.

Check the receiver and transmitter voltage readings against those shown in Figures 1-14A and 1-14B (fold-out from Page 122). Check the resistance readings against the readings shown in Figure 1-15 (fold-out from Page 123). All voltage readings were taken with an 11 megohm input digital voltmeter. Voltages may vary as much as 10%.

Refer to the Receiver Signal Voltage Chart (fold-out from Page 122) if a signal generator is used to troubleshoot the Transceiver.

NOTE: Breaks in the foil of the circuit boards can easily be detected by placing a bright light under the foil side of the board and looking through the board from the lettered side. A break will appear as a hair-line crack in the foil.

Wiring errors and poor soldering are the most common causes of difficulty. Therefore, the first step in troubleshooting is to recheck all wiring against the Pictorials and Schematic diagrams. Often, having a friend check the wiring will locate an error consistently overlooked.

Quite often, soldered connections that appear good will have an insulating coating of rosin between the wire, the terminal, and the solder. This results from insufficient heat being applied when soldering. Many troubles can be eliminated by reheating each connection to make

sure that it is properly soldered as illustrated in the Proper Soldering Techniques section of the Kit Builders Guide. The power cable should be removed from the power supply for such tests. As additional insurance against shock; a screwdriver blade should be used to short from the chassis to the red B+ wires.

If fuses blow instantly when power is applied to the unit, make resistance checks of the power supply, B+ circuits, and filament circuits. Check all tubes for possible shorts. Also refer back to the Initial Test section on Page 100. Check to be sure that all tubes are in their proper locations.

Be sure to read the Circuit Description so that "Cause-and-Effect" reasoning may be employed as the search for the trouble progresses. If some difficulty still persists after the steps outlined in the Troubleshooting Chart have been completed, try to localize the trouble to a particular stage in the circuit by using the voltage and resistance charts. Then refer to the Block Diagram and Schematic to visualize circuit relationships.

A VTVM will be needed to measure voltages. Most of the RF voltages can be measured with the aid of an RF probe.

A grid dip meter or wavemeter and a general coverage receiver are ideal instruments for checking operation of the RF circuits.

NOTE: If there is instability in the unit, check all circuit board mounting screws. These screws should be tight to the chassis and to the circuit board. Be sure lockwashers are against the foil side of the boards for good grounding.

The enclosed relays used in this unit should be troublefree for years of normal use.

DO NOT REMOVE ANY OF THE TUBES OR PILOT LAMPS WITH POWER APPLIED TO THE UNIT. Because of the series-parallel filament circuit arrangement when using a 12 volt supply, removing the tube with power applied may destroy other tubes due to an increase in filament current through them.



Troubleshooting Chart

NOTE: References will often be made to previous Symptoms and Causes. Therefore, each Symptom is identified by a number, and each Possible Cause has an identifying letter. If you are directed, for example, to "check item 1C," refer to Symptom number 1, Possible Cause C.

SYMPTOMS	POSSIBLE CAUSE
1. No power, pilot lamps and tube filaments do not light, no B+ or bias voltage.	A. Power supply switch at off position. B. Power plug wired incorrectly. C. Power cable from power supply wired incorrectly. D. Defective AC snap switch on Function switch. E. In mobile installation, power supply leads reversed to battery. F. Fuses or circuit breakers open. G. Defective power supply. H. Faulty battery or battery cables.
2. Pilot lamps and tube filament light, but no bias or B+ voltage.	A. Check items 1B and 1C. B. Rectifiers defective in power supply. C. Transistors defective in DC power supply.
3. Bias and B+ voltage OK, but pilot lamps and tube filaments do not light.	A. Check items 1B and 1C. B. Large brown-white wires in wire harness open or wired incorrectly.
4. Low and high filament voltages on various tubes or pilot lamps.	A. Check item 3B. B. Brown leads used to balance filament voltages connected incorrectly, or not connected.
5. No regulated B+ (+150).	A. Relay RL2 wired incorrectly. B. Bad OA2 regulator tube, V18. C. Resistor R304 and/or R305 open or wired incorrectly.
6. Regulated B+ voltage too high.	A. Check items 5A and 5B. B. Resistor R304 and/or R305 wrong value.

SYMPTOMS	POSSIBLE CAUSE
7. Regulated B+ voltage too low.	<ul style="list-style-type: none"> A. Check items 5B and 6B. B. Shorted bypass capacitor in regulated B+ line.
8. No screen voltage at tubes V10 and V11.	<ul style="list-style-type: none"> A. Lugs 3, 7, or 11 of relay RL2 wired wrong.
9. High-pitched audio oscillation unaffected by AF GAIN control.	<ul style="list-style-type: none"> A. Red and blue audio output transformer leads reversed.
10. No audio output from speaker or headphones.	<ul style="list-style-type: none"> A. Check items 5A, 5B, and 5C. B. Defective transformer T301. C. Phone Volume control wrong value, shorted, or wired backwards. D. Filter capacitor C304 shorted or installed backwards. E. Audio amplifier output tube V14 defective. F. Coaxial cables connected to AF GAIN control shorted. G. Leads reversed at lugs 3, 7, or 11 of relay RL2. H. Leads reversed at lugs 2, 6, or 10 of relay RL2.
11. No audio output from speaker, but headphone output OK.	<ul style="list-style-type: none"> A. Contacts 1 and 2 of Phones jack open. B. Leads reversed to lugs 1 and 4 of Phones jack. C. Speaker lead connected to wrong phono socket. D. Defective speaker. E. Output transformer green, black, or white leads connected wrong.
12. Low or no audio output from headphones, but speaker output OK.	<ul style="list-style-type: none"> A. Phone Volume control set to its full counterclockwise position. B. Phones jack wired incorrectly. C. Defective headphones.
13. No signal or noise output, but very low hum output can be heard (speaker or phones).	<ul style="list-style-type: none"> A. Check items 10A, 10F, and 10G. B. RFC101 open. C. Product detector tube V13 faulty. D. No carrier generator injection signal at product detector. (Check items 30A through 30F.) E. Red coaxial cable connected to AF GAIN control open or shorted. F. IF transformer T102 misaligned or defective. G. IF amplifier tubes V3 or V4 defective. H. Orange coaxial cable from V12 to crystal filter FL1 open or shorted. I. RF Gain control wired backwards.



SYMPTOMS	POSSIBLE CAUSE
<p>14. No signal output, but noise output can be heard.</p>	<ul style="list-style-type: none"> A. Transformer T201 misaligned or defective. B. No LMO injection signal at the cathode of V12A. (Check items 37A and 37B.) C. Coaxial cable connected between the band-pass and driver plate circuit boards, open or shorted. D. First IF amplifier tube V3 defective. E. Second receiver mixer tube V12A defective. F. No heterodyne oscillator injection signal at the cathode of V11. (Check items 33A through 33I.) G. First receiver mixer V11 or RF amplifier V10 defective. Also check item 4A. H. Coaxial cable connected between relay RL1 and the driver plate circuit board, open or shorted. I. Relay RL1 wired incorrectly. J. Bandpass filter T202 defective. K. Crystal filter FL1 defective. L. Filter switch in CW position. M. FREQ Control switch in wrong position.
<p>15. Audio output with signal, but weak.</p>	<ul style="list-style-type: none"> A. Low B+ supply voltage. B. Coils on driver plate, driver grid, and heterodyne oscillator circuit boards misaligned. C. Check items 4A, 7A, 13A through 13I and 14A through 14K. D. RF Gain control is partially counterclockwise or wired incorrectly.
<p>16. Receiver tends to be unstable, oscillates. (Receiver noise may be extremely high, or many "birdies" appear across tuning range.)</p>	<ul style="list-style-type: none"> A. RF driver and IF circuit board mounting hardware not tight, or lockwashers left out between the chassis and circuit boards. B. Antenna transmission line open or shorted, or has high SWR. C. Supply voltage too high. Check items 6A and 6B. D. Transmitter cut-off bias too low.
<p>17. Sideband reception reversed or highly distorted.</p>	<ul style="list-style-type: none"> A. Carrier generator crystals Y1 and Y2 interchanged. B. CW carrier generator crystal Y3 interchanged with either Y1 or Y2. C. Leads reversed at lugs 13 and 17 on the FREQ Control switch. D. Filter switch in CW position.

SYMPTOMS	POSSIBLE CAUSE
<p>18. S-Meter inoperative, indicates backwards, is inoperative in some METER switch positions, does not zero, or zero shifts on some bands.</p>	<p>A. Leads connected to the meter are reversed. B. Improper wiring of Meter switch. C. Meter Zero control improperly adjusted. D. One of the following resistors is a wrong value: R103, R105, R106, R107, R110, or R115. E. First or second IF amplifier tubes (V3 or V4) defective. F. AVC line shorted to chassis. G. Lugs 4, 8, or 12 of relay RL2 wired wrong. H. V19, wrong type.</p>
<p>18A. S-Meter zero setting shifts on some bands.</p>	<p>A. Heterodyne oscillator coils improperly set. Readjust (see steps on Page 102).</p>
<p>19. No screen voltage at driver tube V7.</p>	<p>A. Relay RL2 not energized. Check items 34A through 34C, and 35A through 35H. B. Lugs 3, 7, and 11 of relay RL2 connected incorrectly.</p>
<p>20. Bias voltage does not shift to operating levels in transmit conditions.</p>	<p>A. Check item 19A. B. Lugs 2, 6, and 10 of relay RL2 wired wrong. C. Bias Adjust control set improperly.</p>
<p>21. No RF output from final, regardless of Mode switch position. (Driver output appears to be OK.)</p>	<p>A. No high voltage B+ at the plates of final amplifier tubes V8 and V9. B. RF choke L901 open. C. Lugs 8 and 12 of relay RL1 wired wrong. D. Bias voltage too high at the grids of V8 and V9. (Check items 20A through 20C.) E. Final controls not adjusted properly. F. Final amplifier tubes V8 and/or V9 defective. G. Rotor in switch on driver plate circuit board 180 degrees out of rotation. H. Final knobs or shafts loose.</p>
<p>22. No RF output from driver regardless of Mode switch position. (Second transmitter mixer appears to be OK.)</p>	<p>A. No B+ voltage at the screen of V7. (Check items 19A and 19B.) B. RFC801 open. C. Bias voltage at grids of V8 and V9 too high. Check items 19A, 20B, and 20C. D. Coils on the driver plate and grid circuit boards misaligned. E. Driver Preselector control not adjusted properly. F. Driver tube V7 defective.</p>



SYMPTOMS	POSSIBLE CAUSE
23. No RF output.	<ul style="list-style-type: none"> A. Filter switch in CW position with no CW filter installed. B. FREQ Control switch in wrong position C. Antenna shorted. D. No B+ 800 volts.
24. No RF output from second transmitter mixer, regardless of the Mode switch setting. (First transmitter mixer appears to be OK.)	<ul style="list-style-type: none"> A. Check items 5A through 5C, 19A, 19B, 22D, and 22E. B. No heterodyne oscillator injection signal at cathode of V6. (Check items 33A through 33K.) C. Coaxial cable connected between the bandpass and driver plate circuit board open or shorted. D. Second transmitter mixer tube V6 defective. E. Check item 25B.
25. No output from first transmitter mixer regardless of the Mode switch position. (First IF amplifier appears to be OK.)	<ul style="list-style-type: none"> A. FREQ Control switch in wrong position. B. Check items 19A, 19B, 20B, 20C, 22D, and 22E. C. No LMO output signal to cathode of V5 (pin 7). D. First transmitter mixer tube V5A defective. E. Blue coaxial harness cable connected between the IF and bandpass coupler circuit boards open or shorted. F. Capacitors C111 and C402 wrong value. G. Bandpass filter T202 defective. H. Check item 25B.
26. No RF output from first IF amplifier, regardless of the Mode switch position. (Isolation amplifier output appears to be OK.)	<ul style="list-style-type: none"> A. Check items 14A, 14C, 14D, 14K, 19A, and 19B. B. FILTER switch in CW position with no CW filter installed.
27. No RF output from isolation amplifier, regardless of the Mode switch position.	<ul style="list-style-type: none"> A. Check items 20B and 20C. B. Resistors R18, R19, R23, R24, R937, and/or R938 wrong value. C. Transformer T1 misaligned or faulty. D. Isolation amplifier tube V2 defective. E. Carrier oscillator not operating. (Check items 30B through 30E, and 31B through 31E.)

SYMPTOMS	POSSIBLE CAUSE
<p>28. No RF output with the Mode switch in USB or LSB, but output in Tune or CW positions OK.</p>	<p>A. Check items 10C, 10D, 10E, 20A, and 25A. B. No carrier injection signal to balanced modulator. (Check items 30B through 30E, and 31B through 31E.) C. Balanced modulator diodes CR1 through CR4, installed improperly, wrong type, or defective. D. Orange and/or yellow coaxial cables connected to the MIC/CW Level control open or shorted. E. Wafer 1F or 1R of the Mode switch wired incorrectly. F. MIC connector wired wrong. G. Speech amplifier tube V1 defective. H. Microphone defective. I. MIC/CW Level control defective.</p>
<p>29. No RF output with the Mode switch in Tune or CW, but output in LSB or USB OK.</p>	<p>A. Check items 19A, 19B, 20B, 20C, 29B, 30C, 30D, and 30E. B. MIC/CW Level control defective. C. Rear wafer of Mode switch wired wrong. D. Carrier oscillator crystals in wrong sockets.</p>
<p>30. No carrier oscillator injection signal with the Mode switch in Tune or CW positions, but LSB and USB output OK.</p>	<p>A. Check items 19A and 19B. B. CW crystal Y3 improper frequency or defective. C. Lugs 1, 5, and/or 9 of the Mode switch wired incorrectly. D. Incorrect wiring of Mode switch wafers 1F or 2R. E. Tube V16 defective.</p>
<p>31. No carrier oscillator injection signal with the Mode switch in either LSB or USB positions. Tune and CW output OK.</p>	<p>A. Check items 19A and 19B. B. Black coaxial cable from IF circuit board to modulator circuit board shorted. C. USB crystal Y1, or LSB crystal Y2, improper frequency or defective. D. Capacitors C4 through C8, C16 and C17, wrong value. E. Resistors R6 through R9, or R11, wrong value. F. Tube V16 defective.</p>
<p>32. Very low output in USB or LSB modes.</p>	<p>A. Filter switch in CW position. B. Microphone output level or impedance too low.</p>
<p>33. Transmitter will not key in CW.</p>	<p>A. V15 not operating. B. Wrong value of C317. C. D904 shorted or open.</p>

SYMPTOMS	POSSIBLE CAUSE
34. No LMO injection signal at cathodes of V5 or V12.	A. Check items 5A, 5B, and 5C. B. FREQ Control switch not in the LMO position, or wired wrong. C. The violet, orange, or white coaxial cables connected to the FREQ Control switch, or the coaxial cable between the FREQ Control switch and the LMO, wired incorrectly, shorted, or open. D. LMO power supply voltage incorrect or +10 volts to power supply incorrect. E. Transistor Q1 shorted. F. Defective LMO unit. If after making all the above checks it is determined that the LMO unit is defective, return the complete LMO to the Heath Company. See Page 15 of the Kit Builders Guide.
35. LMO frequency does not shift properly with Mode switch in various positions.	A. Check items 2A, 2B, 2C, 5A, 5B, 5C, 30B, 30D, 31C, 32D, and 32E. B. Mode switch wafer 1F wired incorrectly. C. Resistor R307 wrong value.
36. No heterodyne oscillator injection signal at cathodes of V6 and V11.	A. Check items 5A, 5B, and 5C. B. One of the crystals Y501 through Y508 defective, depending on the band being used. C. Red coaxial cable from heterodyne oscillator circuit board to bandpass circuit board, open or shorted. D. Capacitors C208 or C223 wrong value. E. Tube V19 defective or wrong type. F. Coils L601 through L608 misaligned or faulty. G. Capacitor C604 wrong value. H. No 150 V B+ voltage to the heterodyne oscillator circuit board. I. Rotors reversed 180 degrees in the switch wafer on the crystal or heterodyne oscillator circuit boards.
37. Relays RL1 and RL2 do not energize with the Mode switch in the Tune position.	A. Tube V12B defective. B. Relays RL1 or RL2 defective. C. Wafer 2F of Mode switch wired incorrectly.
38. No LMO output.	A. Check 10V LMO Power Supply. B. FREQ Control switch in wrong position. C. Coaxial cable shorted or open.
39. No 10V from LMO Power Supply.	A. Voltage dropping lamp open. B. Zener diode installed backward. C. Transistor Q1 open. D. Jumper wire between pins 6 and 8 of Power Socket not installed (for mobile use).

SYMPTOMS	POSSIBLE CAUSE
<p>40. Relays RL1 and RL2 will not energize with Mode switch in LSB or USB, and Function switch in VOX position.</p>	<p>A. Check items 10C, 10D, 10E, 28G through 28J, 35A, 35B, and 35C. B. VOX Sensitivity control improperly adjusted. C. Tube V17A defective or wrong type. D. Diode D201 wrong type or installed backward. E. Zener diode D202 installed backward or defective. F. Function switch wired incorrectly. Check the red-red-white wire to lug 3. G. Anti-Trip control set too high. H. Function switch in the CAL position.</p>
<p>41. Relays energize and stay energized regardless of VOX SEN control setting.</p>	<p>A. Check items 35B, 36D, and 36E. B. Anti-Trip rectifiers D1 and D2 installed backward. C. PTT switch on microphone stuck closed or shorted. D. Key closed.</p>
<p>42. Transmitter tends to be unstable.</p>	<p>A. Final and/or driver neutralization not proper. B. Mounting hardware for Final and Loading capacitors not tight. C. Mounting hardware for Modulator and RF driver circuit board not tight. Lockwashers between circuit boards and chassis left out. D. Check items 16C and 16D. E. Coils L802 through L805 and/or L801 misaligned. F. Antenna impedance wrong. G. Coil shield cover loose. H. Ground clips for tube shields bent out.</p>
<p>43. Receiver has slow recovery from transmit condition.</p>	<p>A. Diode D101 defective.</p>
<p>44. Grid drive falls off.</p>	<p>A. Excessive heat due to restricted air circulation. B. Incorrect bias setting. C. Improper load to RF output. D. Gassy 6146 tubes.</p>
<p>45. Zero setting of main tuning dial changes considerably from band to band.</p>	<p>A. 100 kHz calibrator is not set exactly at 100 kHz.</p>

SPECIFICATIONS

RECEIVER

Sensitivity.	Less than 0.35 microvolt for 10 dB signal-plus-noise to noise ratio for SSB operation.
SSB Selectivity.	2.1 kHz minimum at 6 dB down, 5 kHz maximum at 60 dB down (3.395 MHz filter). (2:1 nominal shape factor at 60:6 dB.)
CW Selectivity (With SBA-301-2 CW Filter Installed).	400 Hz minimum at 6 dB down, 2.0 kHz maximum at 60 dB down.
Input.	Low impedance for unbalanced coaxial input.
Output Impedance.	8 Ω speaker, and high impedance headphone.
Power Output.	2 watts with less than 10% distortion.
Spurious Response.	Image and IF rejection better than 50 dB. Internal spurious signals below equivalent antenna input of 1 microvolt.

TRANSMITTER

DC Power Input.	SSB: (A3J emission) 180 watt P.E.P. (normal voice: continuous duty cycle). CW: (A1 emission) 170 watts (50% duty cycle).
RF Power Output.	100 watts on 80 through 15 meters; 80 watts on 10 meters (50 Ω nonreactive load).
Output Impedance.	50 Ω to 75 Ω with less than 2:1 SWR.
Oscillator Feedthrough Or Mixer Products.	55 dB below rated output.
Harmonic Radiation.	45 dB below rated output.
Transmit-Receive Operation.	SSB: PTT or VOX. CW: Provided by operating VOX from a keyed tone, using grid-block keying.
CW Side-Tone.	Internally switched to speaker or headphones, in CW mode. Approximately 1000 Hz tone.
Microphone Input.	High impedance with a rating of -45 to -55 dB.
Carrier Suppression.	50 dB down from single-tone output.
Unwanted Sideband Suppression.	55 dB down from single-tone output at 1000 Hz reference.
Emissions not possible or not recommended.	A0, A2, A3, A3b, A4 through A9, F0 through F9, and P0 through P9.

Third Order Distortion.	30 dB down from two-tone output.
RF Compression (TALC*).	10 dB or greater at .1 mA final grid current.

GENERAL

Frequency Coverage.	3.5 to 4.0; 7.0 to 7.3; 14.0 to 14.5; 21.0 to 21.5; 28.0 to 28.5; 28.5 to 29.0; 29.0 to 29.5; 29.5 to 30.0 (megahertz).
Frequency Stability.	Less than 100 hertz per hour after 10 minutes warmup from normal ambient conditions. Less than 100 Hz for $\pm 10\%$ line voltage variations.
Modes Of Operation.	Selectable upper or lower sideband (suppressed carrier) and CW.
Visual Dial Accuracy.	Within 200 Hz on all bands.
Electrical Dial Accuracy.	Within 400 Hz after calibration at nearest 100 kHz point.
Dial Mechanism Backlash.	Less than 50 Hz.
Calibration.	100 kHz crystal.
Audio Frequency Response.	350 to 2450 Hz.
Phone Patch Impedance.	8 Ω receiver output to phone patch; high impedance phone patch input to transmitter.
Front Panel Controls.	Main (LMO) tuning dial. Driver tuning and Preselector. Final tuning. Final loading. Mic and CW Level control. Mode switch. Band switch. Function switch. Freq Control switch. Meter switch. RF Gain control. Audio Gain control. Filter switch.

*Triple Action Level Control™

Internal Controls.

- VOX Sensitivity.
- VOX Delay.
- Anti-trip.
- Carrier Null (control and capacitor).
- Meter Zero control.
- CW tone volume.
- Relative Power Adjust control.
- Bias.
- Phone Vol (headphone volume).
- Neutralizing.

Tube Complement.

- OA2 Regulator (150 V).
- 6HS6 RF amplifier.
- 6AU6 1st receiver mixer.
- 6AU6 Isolation amplifier.
- 6AU6 1st IF amplifier.
- 6AU6 2nd IF amplifier.
- 6BN8 Product detector and AVC.
- 6CB6 2nd transmitter mixer.
- 6CL6 Driver.
- 6EA8 Speech Amplifier and cathode follower.
- 6EA8 1st transmitter mixer and crystal oscillator.
- 6EA8 2nd receiver mixer and relay amplifier.
- 6EA8 CW side-tone oscillator and amplifier.
- 6GW8 Audio amplifier and audio output.
- 12AT7 Heterodyne oscillator and cathode follower.
- 12AT7 VOX amplifier and calibrator oscillator.
- 12AU7 Sideband oscillator.
- 6146 Final amplifiers (2).

Diode Complement.

- 6 Germanium Diodes: Balanced modulator, RF sampling, and crystal calibrator harmonic generation.
- 10 Silicon Diodes: ALC rectifiers, Anti-Trip rectifiers, and DC blocking, LMO Power Supply.
- 2 Zener Diodes: Cathode bias, LMO Power Supply.

Transistor.

- 2N3567 LMO Power Supply.

CIRCUIT DESCRIPTION

Refer to the Block Diagram (fold-out from Page 134) and to the Schematic (fold-out from Page 165) while reading the Circuit Description. Small sections of the Schematic are also included in this Description to make the circuits easier to follow.

Note that the receiver circuits are across the bottom, and the transmitter circuits are across the top of the Schematic and Block Diagrams. Also, several of the circuits that are used for transmitting are also used for receiving (such as the crystal filter and the first IF amplifier). These circuits, which are shown in both the transmitter and receiver portions of the Block Diagram, are identified in the Block Diagram by dotted lines.

Each rotary switch wafer is identified by the front panel name of the switch, and by a letter-number designation that shows the position of that wafer in the switch. See Figure 2-1.

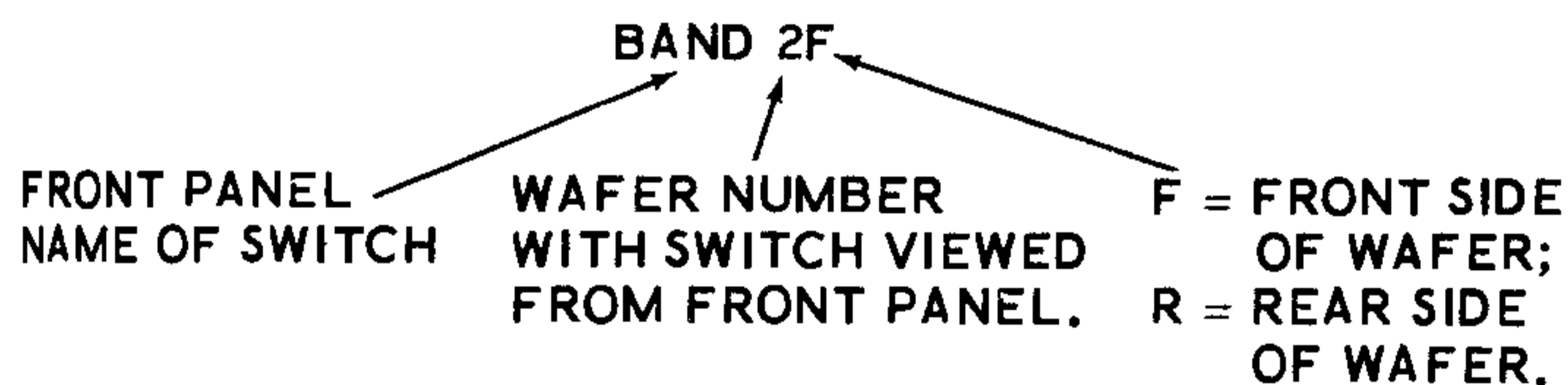

Figure 2-1

Letter-number designations for the resistors, capacitors, coils, etc., are placed in the following groups:

- 0- 99 Parts on modulator circuit board.
- 100-199 Parts on IF circuit board.
- 200-299 Parts on bandpass circuit board.
- 300-399 Parts on audio circuit board.
- 400-499 Parts on RF-driver circuit board.
- 500-599 Parts on crystal circuit board.
- 600-699 Parts on heterodyne oscillator circuit board.
- 700-799 Parts on driver grid circuit board.
- 800-899 Parts on driver plate circuit board.
- 900-999 Parts mounted on the chassis.

TRANSMITTER CIRCUITS

The chart in Figure 2-2 lists the various frequencies that will be found throughout the transmitter on each band. The transmitted lower sideband frequency of 3.895 MHz, modulated with a 1400 hertz audio tone, which is shown on the first line, will be used when tracing through the transmitter circuits. The other frequencies referred to in this Circuit Description will also be found on the first line. Mode switch is in the LSB position, and the relays are closed (transmitting). Function switch is in VOX.

BAND	CARRIER OSCILLATOR (3393.6 kHz plus 1400 Hz modulation), CRYSTAL FILTER AND IF FREQUENCIES	LMO FREQUENCY (BETWEEN 5 AND 5.5)	SIGNAL FREQUENCY AT BANDPASS FILTER (BETWEEN 8.395 AND 8.895)	HETERODYNE OSCILLATOR FREQUENCY (CRYSTAL FIXED)	TRANSMITTED SIGNAL FREQUENCY
3.5 to 4	3.395	5.105	8.5	12.395	3.895
7 to 7.5	3.395	5.3	8.695	15.895	7.2
14 to 14.5	3.395	5.3	8.695	22.895	14.2
21 to 21.5	3.395	5.2	8.595	29.895	21.3
28 to 28.5	3.395	5.4	8.795	36.895	28.1
28.5 to 29	3.395	5.3	8.695	37.395	28.7
29 to 29.5	3.395	5.3	8.695	37.895	29.2
29.5 to 30	3.395	5.4	8.795	38.395	29.6

All frequencies are in MHz.

Figure 2-2

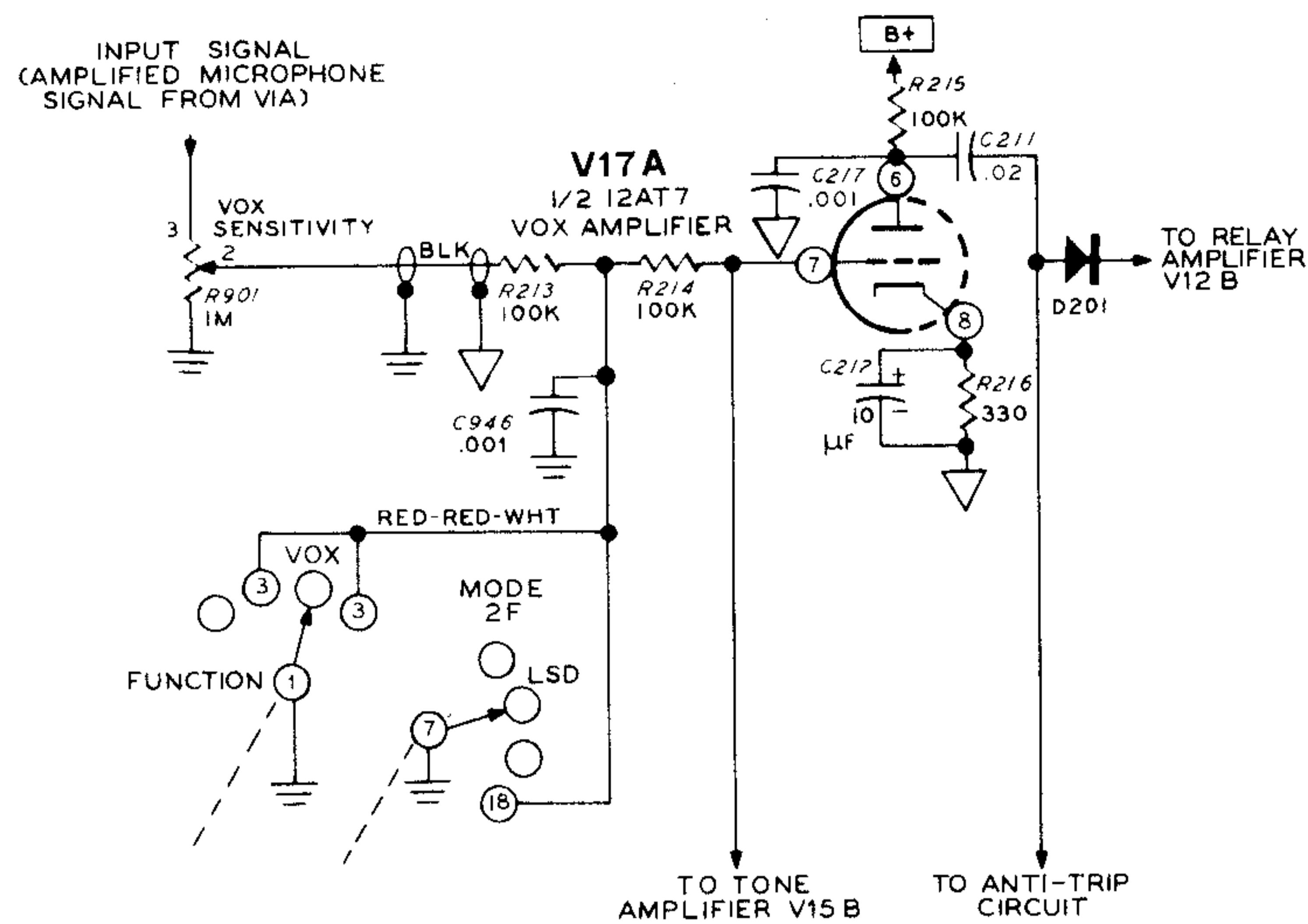

Figure 2-3

VOX Amplifier (Figure 2-3)

The Transceiver can be switched from receive to transmit by either the VOX (voice operated transmitter) or the push-to-talk method. The VOX circuit works in the following manner:

The audio signal from the microphone is coupled through speech amplifier V1A and capacitor C9 to the VOX Sensitivity control. From the arm of this control, for VOX operation, the signal is coupled through resistors R213 and R214 to the grid of VOX amplifier V17A. The signal is amplified in V17A. It is then coupled through capacitor C211, rectified by diode D201, and applied to relay amplifier V12B, which actuates the transmit-receive relays.

In the PTT and Calibrate positions of the Function switch, and in the CW position of the Mode switch, the lead from the VOX Sensitivity control to the grid of V17A is connected to ground. This keeps stray microphone signals from activating the VOX circuit during PTT and CW operation, or during calibration.

Relay Amplifier (Figure 2-4)

Relay amplifier V12B is held in cutoff during receive operation by the positive voltage that is maintained at its cathode by zener diode D202. V12B is made to conduct for transmit operation by the VOX voltage at its grid, or by the push-to-talk switch on the microphone which shorts the cathode to ground. (The cathode of V12B is also shorted to ground by wafer 2F of the Mode switch in the Tune position.) Diode D201 rectifies the audio signal from the VOX amplifier so that a positive voltage appears at the grid of relay amplifier V12B. The positive voltage at the grid causes the relay amplifier to conduct, and the plate current of V12B causes relays RL1 and RL2 to close and place all circuits in the transmit mode of operation.

The VOX hold-in time is adjusted by varying the discharge time for capacitor C213 with the VOX Delay control.

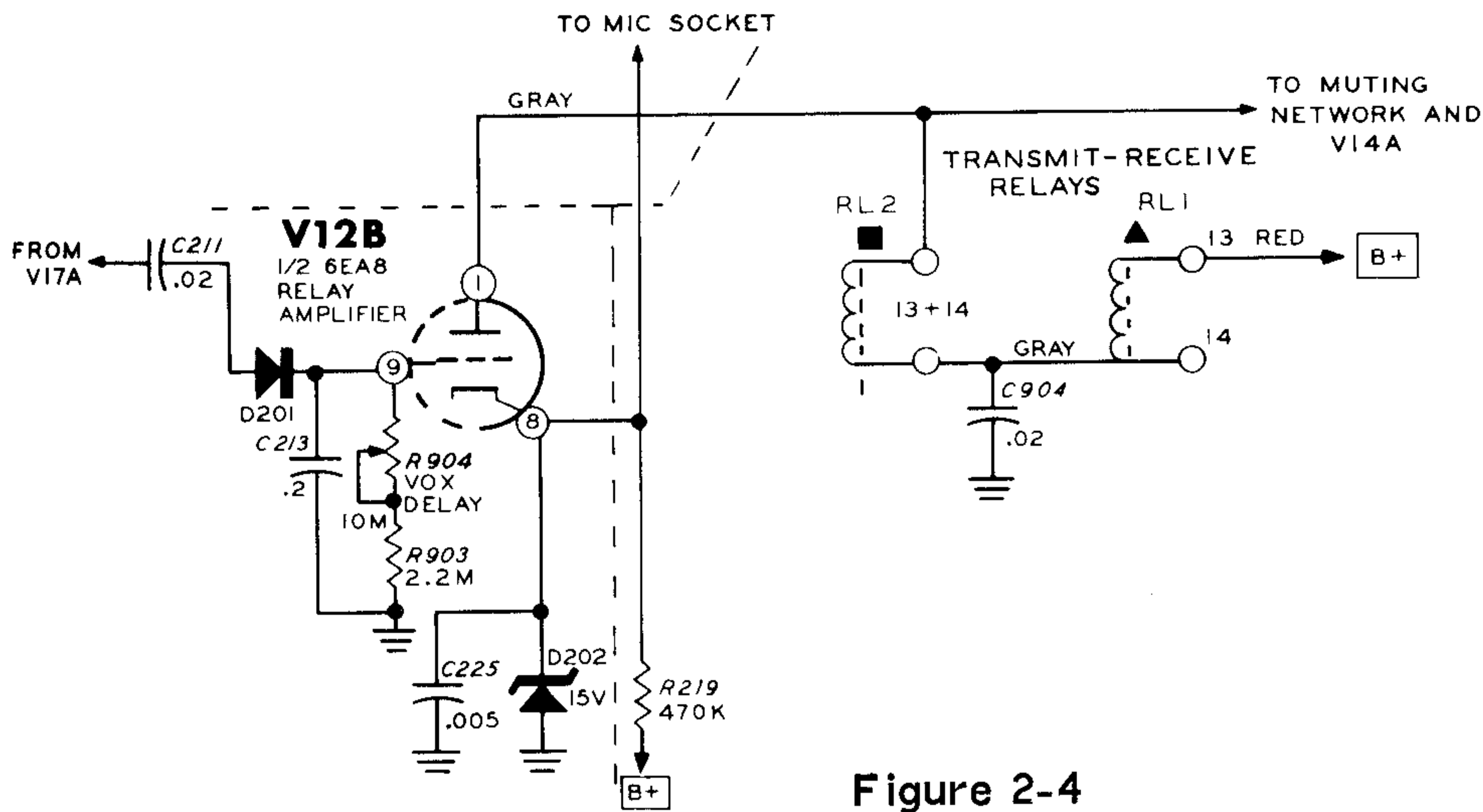

Figure 2-4

Anti-Trip Circuit (Figure 2-5)

The anti-trip circuit is used in the receive mode of operation to keep the speaker signals from activating relay amplifier V12B.

An audio signal is coupled through capacitor C305 from audio power amplifier V14B to the Anti-Trip control. This audio signal is then

coupled through isolation resistor R25 and rectified by diodes D1 and D2, resulting in a negative DC voltage across capacitor C25 and resistor R16. This negative voltage is then coupled through resistor R27 to the grid circuit of relay amplifier V12B, where it cancels out the positive voltage from the VOX amplifier. Thus, with no positive voltage at its grid, relay amplifier V12B remains cut off, and the relays remain in the receive position.

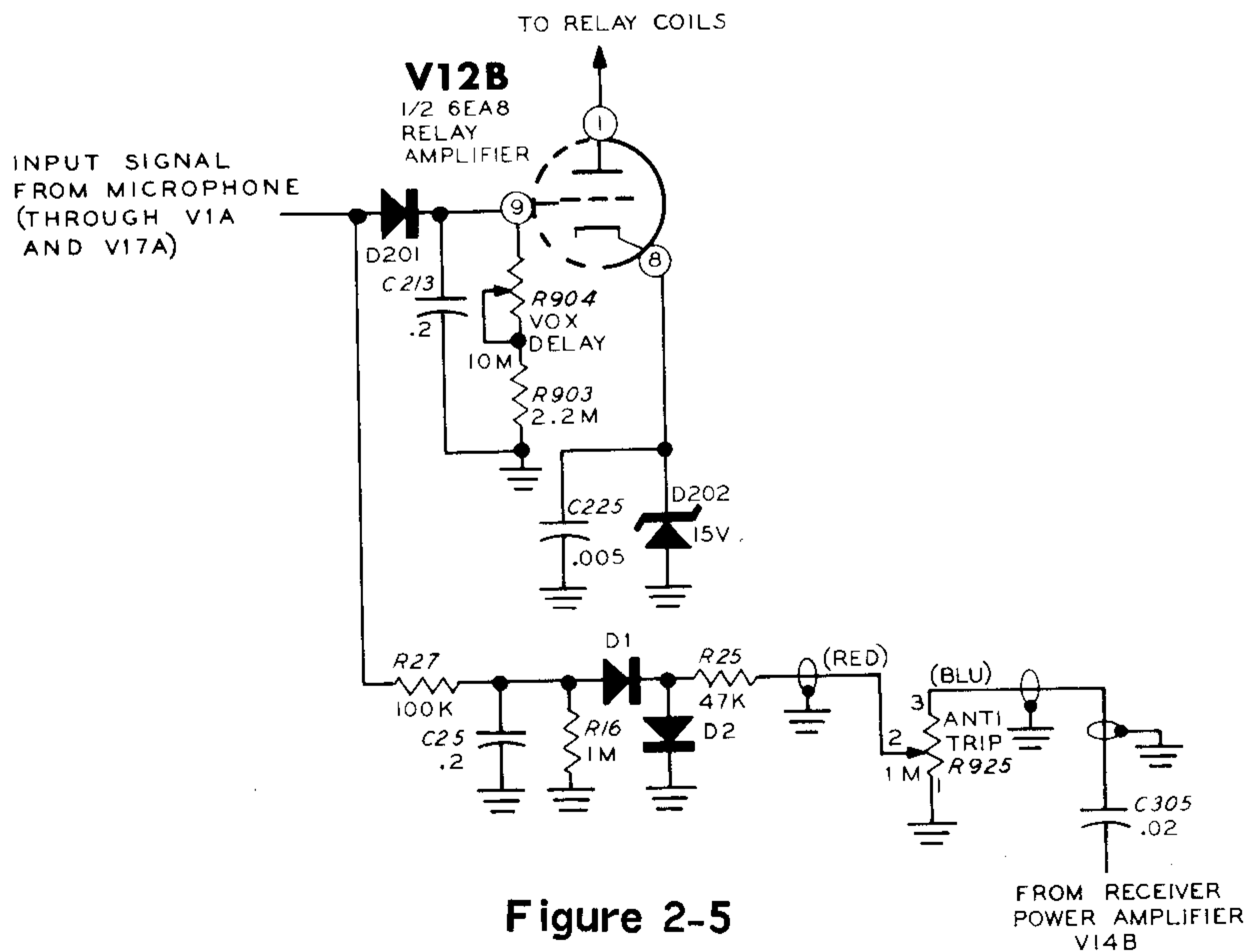

Figure 2-5

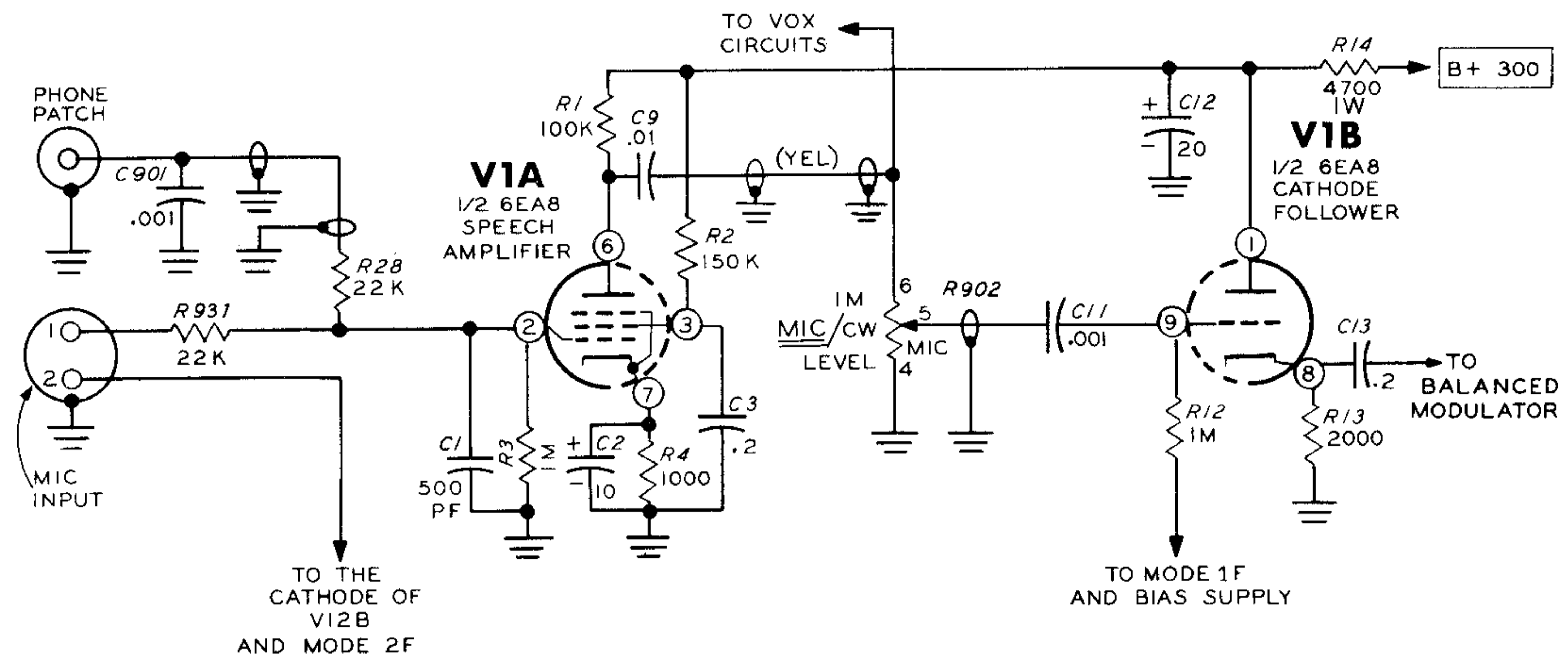

Figure 2-6

Speech Amplifier And Cathode Follower (Figure 2-6)

The audio signal from the microphone is coupled directly from lug 1 of the Microphone input socket to the grid of speech amplifier V1A. Lug 2 of the Microphone input socket is returned to ground through the push-to-talk switch on the microphone. The cathode of relay amplifier V12B is also connected to lug 2 so it will be returned to ground when the push-to-talk switch is depressed, to operate the transmit relays.

Capacitor C1, at the grid of V1A, limits the high frequency response of this stage and passes to ground any RF signals present at this point. The amplified signal from the plate of V1A is coupled through capacitor C9 to the Microphone Level section of the Mic/CW Level control and also to the VOX amplifier circuit.

The setting of the Microphone Level control determines the amount of modulation since it adjusts the amount of speech signal that is coupled through cathode follower V1B to the balanced modulator circuit. For LSB and USB operation, V1B grid resistor R12 is returned to ground through wafer 1F of the Mode switch and contacts 6 and 10 of relay RL2. When the

Mode switch is in the Tune or CW position, cathode follower V1B is cut off by a bias voltage that is supplied to it from the junction of bias voltage divider resistors R308 and R309.

Carrier Oscillator (Figure 2-7)

The carrier oscillator consists of two Colpitts crystal oscillators. These oscillators supply an RF signal to the balanced modulator for transmit operation, and a heterodyne signal to product detector stage V13 for receive operation. Tube V16A and crystal Y1 (3396.4 kHz) serve as the USB (upper sideband) carrier oscillator, and tube V16B with crystals Y2 (3393.6 kHz) and Y3 (3395.4 kHz) acts as the LSB (lower sideband) and CW carrier oscillator.

The desired carrier oscillator, V16B for the transmitted frequency being used in this Description (3393.6 kHz), is placed in operation by wafer 1R of the Mode switch which connects its plate circuit to B+. Wafer 2R of the Mode switch connects the proper crystal to the grid of V16B: Y2 for LSB operation and Y3 for tune or CW transmit operation.

When the Mode switch is in the CW position, B+ is connected through part of relay RL1 to either V16A or V16B.

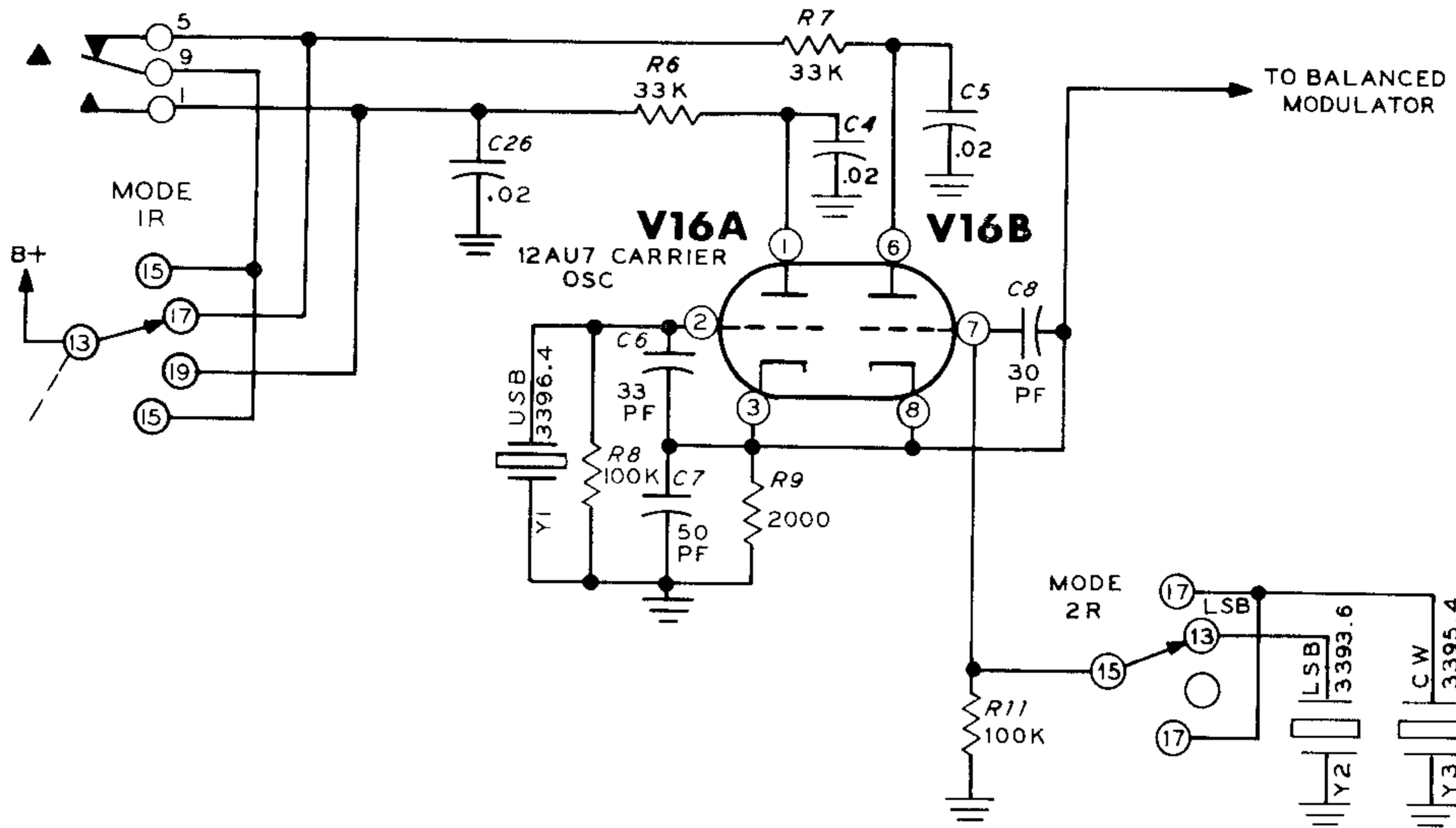

Figure 2-7

For receiving CW signals, lugs 9 and 1 of relay RL1 place tube V16A and crystal Y1 in operation. For transmitting CW, lugs 9 and 5 of relay RL1 place tube V16B and crystal Y3 in operation.

When receiving CW signals, the receiver is automatically tuned 1 kHz below the incoming signal (this signal is zero beat against your transmitting frequency) by V16A and crystal Y1. When transmitting, tube V16B and crystal Y3 cause the output signal of the Transceiver to be at the same frequency as the incoming signal from the other station.

Balanced Modulator (Figure 2-8)

Diodes CR1, CR2, CR3, and CR4, are connected in a ring type balanced modulator circuit. When the audio signal from cathode follower V1B and the RF signal from carrier oscillator V16 are applied to this balanced modulator, two additional frequencies are produced: one is equal to the sum of the audio and carrier frequencies; and the other is equal to the difference between them. These sum and difference frequencies are the upper and lower sidebands; and only these upper and lower sideband signals appear at the output of the balanced modulator circuit.

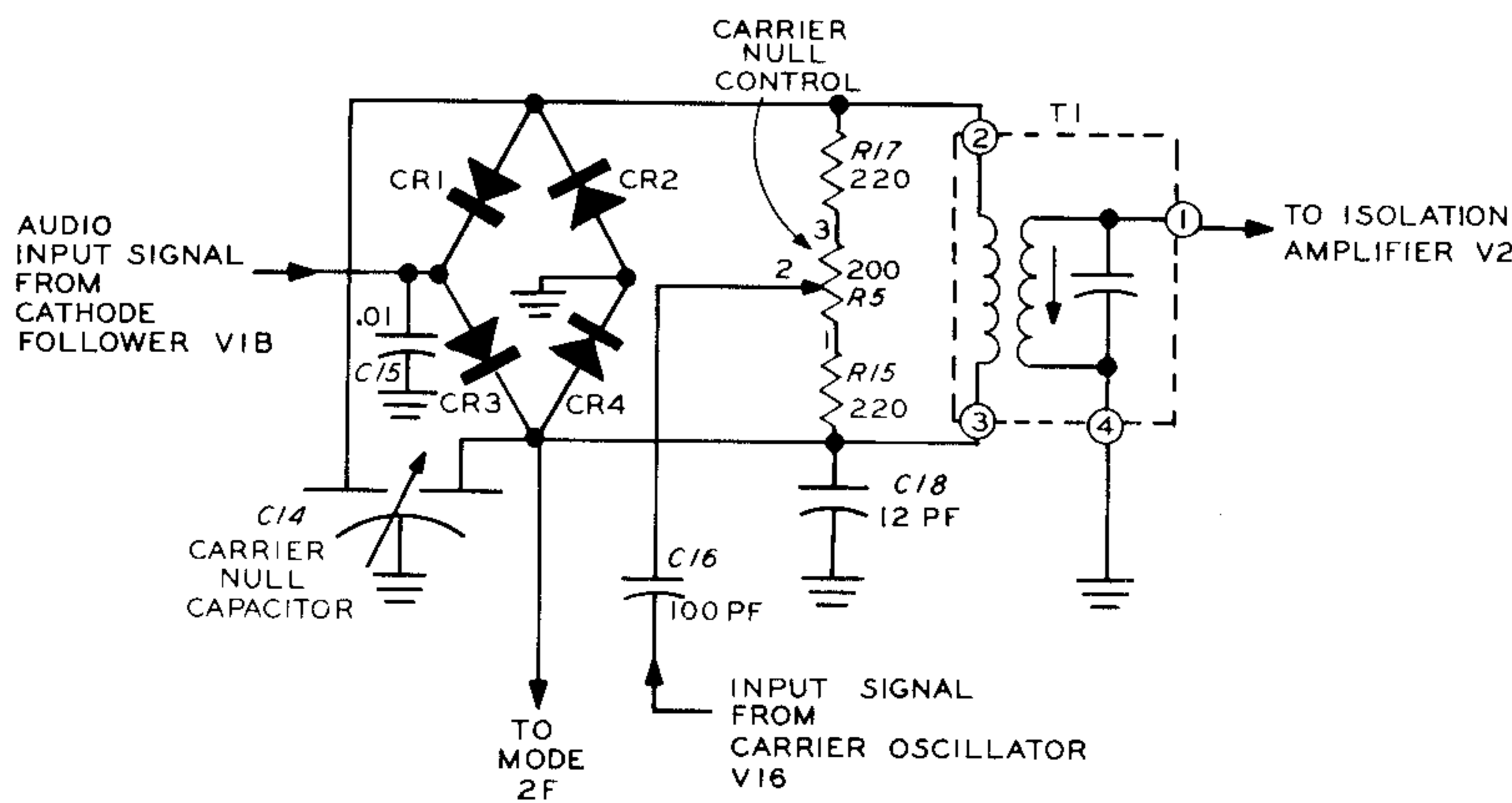

Figure 2-8

The 3393.6 kHz carrier oscillator signal is applied through capacitor C16 and across a bridge circuit that consists of the Carrier Null control, resistors R15 and R17, and diodes CR1, CR2, CR3 and CR4 of the modulator diode ring. See Figure 2-8. The carrier signal is balanced out by the Carrier Null control and the Carrier Null capacitor; so there is no output signal from this circuit (until an audio signal is applied).

The audio signal that is coupled to diodes CR1, CR2, CR3, and CR4 from cathode follower V1B unbalances the modulator at an audio rate, causing the sum and difference sideband frequencies to appear at the output of balanced modulator transformer T1. When no audio signal appears at the input, there is no output signal from the balanced modulator circuit. Capacitor C15 is an RF bypass.

When the Mode switch is turned to the CW position, wafer 2F connects one side of the diode ring to ground. This ground connection unbalances the nulled circuit and the unbalance causes an RF output signal to be produced at the secondary of balanced modulator transformer T1. This signal is then coupled through capacitor C22 to isolation amplifier V2. The secondary of transformer T1 is tuned to the CW carrier frequency.

Isolation Amplifier (Figure 2-9)

Both the upper and lower sideband signals from the balanced modulator circuit are coupled through capacitor C22 to the cathode of isolation amplifier V2. V2 isolates the balanced modulator circuit from the crystal filter, and provides proper impedance matching to the crystal

filter. The gain of isolation amplifier V2 is varied by the ALC (automatic level control) voltage that is connected to its grid circuit through resistors R21 and R22. The complete ALC circuit will be described later under the heading ALC Circuit.

When transmitting, the output of V2 is coupled through capacitor C506 to the crystal filter. In the CW mode of operation, the gain of V2 is controlled by the CW section of the Mic/CW Level control. This control supplies a variable negative bias to the grid of V2 through wafer 1R of the Mode switch and resistors R22 and R21.

B+ is supplied to the screen of V2 in the transmit mode only, through resistor R937 and contacts 7 and 11 of relay RL2.

Crystal Filter (Figure 2-10)

Crystal filter FL1 has a center frequency of 3395 kHz and a usable bandwidth of 2.1 kHz (3393.95 kHz to 3396.05 kHz at the 6 dB points). See Figure 2-10. This filter, in the LSB mode of operation, passes only the sum frequencies (the 3393.6 kHz carrier frequency plus all the audio frequencies from 350 to 2450 Hz), which contain the upper side band intelligence. The carrier amplitude itself, as shown in Figure 2-10, is further reduced 20 dB by the crystal filter. This attenuation plus the attenuation of the balanced modulator gives an ultimate carrier attenuation of at least 50 dB. (The apparent frequency discrepancy here in sidebands and carrier is overcome later, when the sidebands are inverted in the second mixer.)

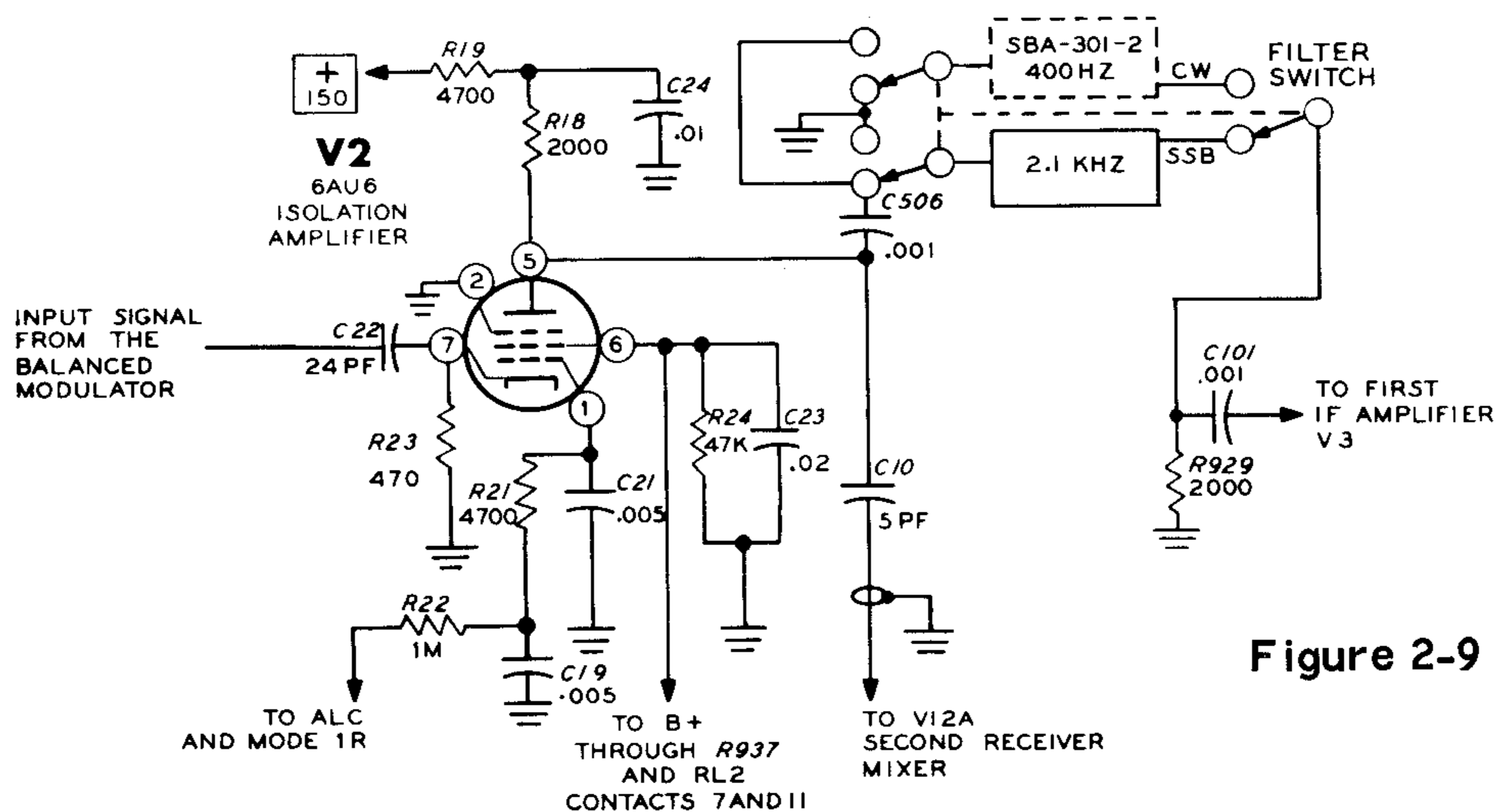

Figure 2-9

IF Amplifier (Figure 2-11)

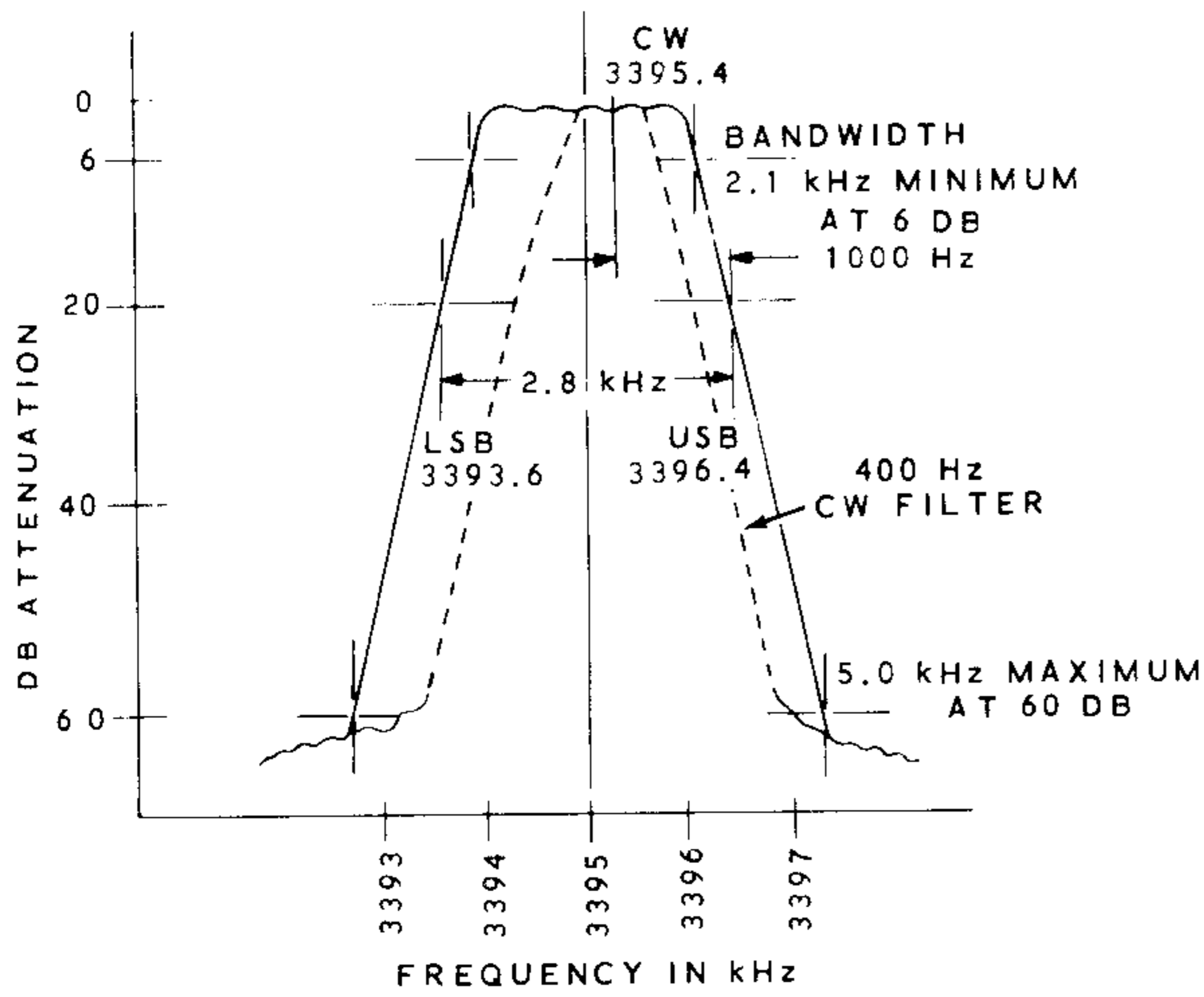

Figure 2-10

In the USB Mode, the filter passes only the difference frequencies (the 3396.5 kHz carrier oscillator frequency minus the audio frequencies from 350 to 2450 Hz); this contains the lower sideband intelligence. In the CW Mode, a carrier of 3395.4 kHz passes through the crystal filter with no attenuation.

If the SBA-301-2 Accessory CW Crystal Filter is installed, the signal passes through it when the Filter switch is in CW. The 400 Hz bandpass of the CW Filter will not pass the normal audio range, therefore making SSB signals unintelligible.

IF Amplifier V3 amplifies the signal received from crystal filter FL1. The second IF amplifier, V4, is not used in transmit operation. IF transformer T102, which is tuned to 3.395 MHz acts as the plate load for V3. The output signal from V3 is then coupled through capacitor C111 to the grid of first transmitter mixer stage V5A. The 6.8 MHz trap is used to remove the second harmonic of the 3.395 MHz signal.

ALC voltage is applied through lugs 8 and 12 of relay RL2 to the grid circuit of V3 to provide automatic level control for the transmitted signal. When the Mode switch is in the CW and Tune positions, the gain of IF amplifier V3 is controlled by a variable DC bias applied to its grid. This bias voltage, which originates at the arm of the Mic/CW Level control, is coupled to V3 through wafer 1R of the Mode switch, and through lugs 8 and 12 of relay RL2.

The front panel meter, in the ALC position, is connected in a DC bridge between the screen and cathode circuits of V3. The meter circuits are explained separately on Page 154 of this Circuit Description.

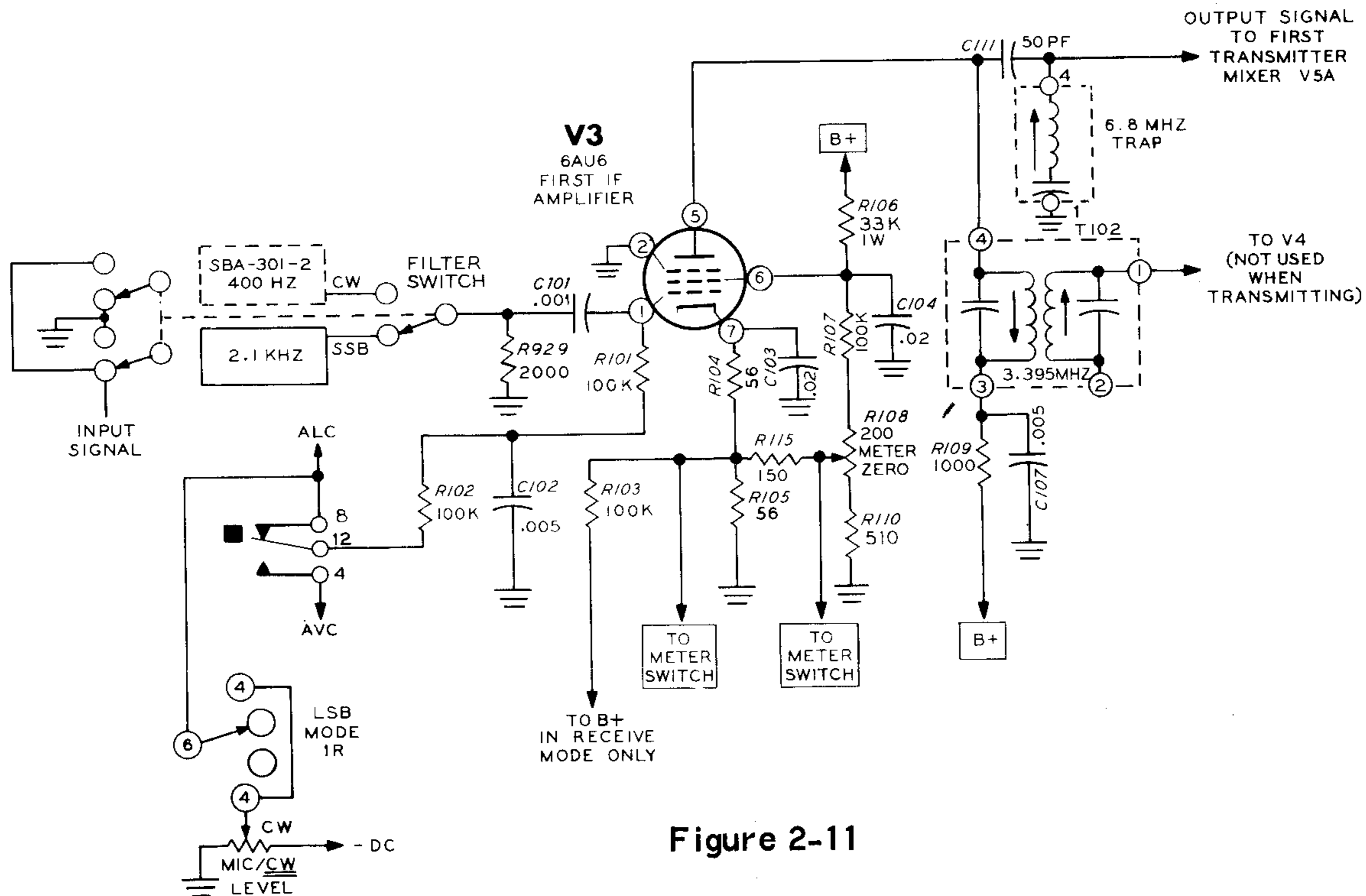

Figure 2-11

LMO/Crystal Oscillators (Figure 2-12)

An 8.5 MHz signal is required at the output of first mixer tube V5A to produce the correct output frequency on the 3.5 to 4 MHz band, which is being used in this Circuit Description. This 8.5 signal is obtained by mixing the 3.395 MHz IF signal at the grid of V5A with the oscillator signal that is applied to its cathode from the Freq Control switch.

The Freq Control switch receives signals from the LMO (linear master oscillator), or from crystal oscillator V5B. The LMO is a very stable variable oscillator that can be continuously tuned linearly over a frequency range of 5 to 5.5 MHz. Crystal controlled Colpitts oscillator V5B may be switched into the circuit in place of the LMO for crystal controlled operation of the Transceiver.

The Freq Control switch performs the following functions: In the LMO position, the signal is connected from the LMO to first transmitter mixer V5A and to first receiver mixer V11. In the Locked AUX position the output of crystal oscillator V5B is connected to first transmitter mixer V5A and to second receiver mixer V12A. In the Unlocked AUX position, the output of crystal oscillator V5B is connected to first transmitter mixer V5A, and the LMO output is connected to second receiver mixer V12A.

The term Locked means that the transmitter and receiver sections are controlled by a common oscillator. This causes them to always be locked on identical frequencies.

The term Unlocked means that the Transmitter and receiver sections are controlled by separate oscillators and their frequencies may differ.

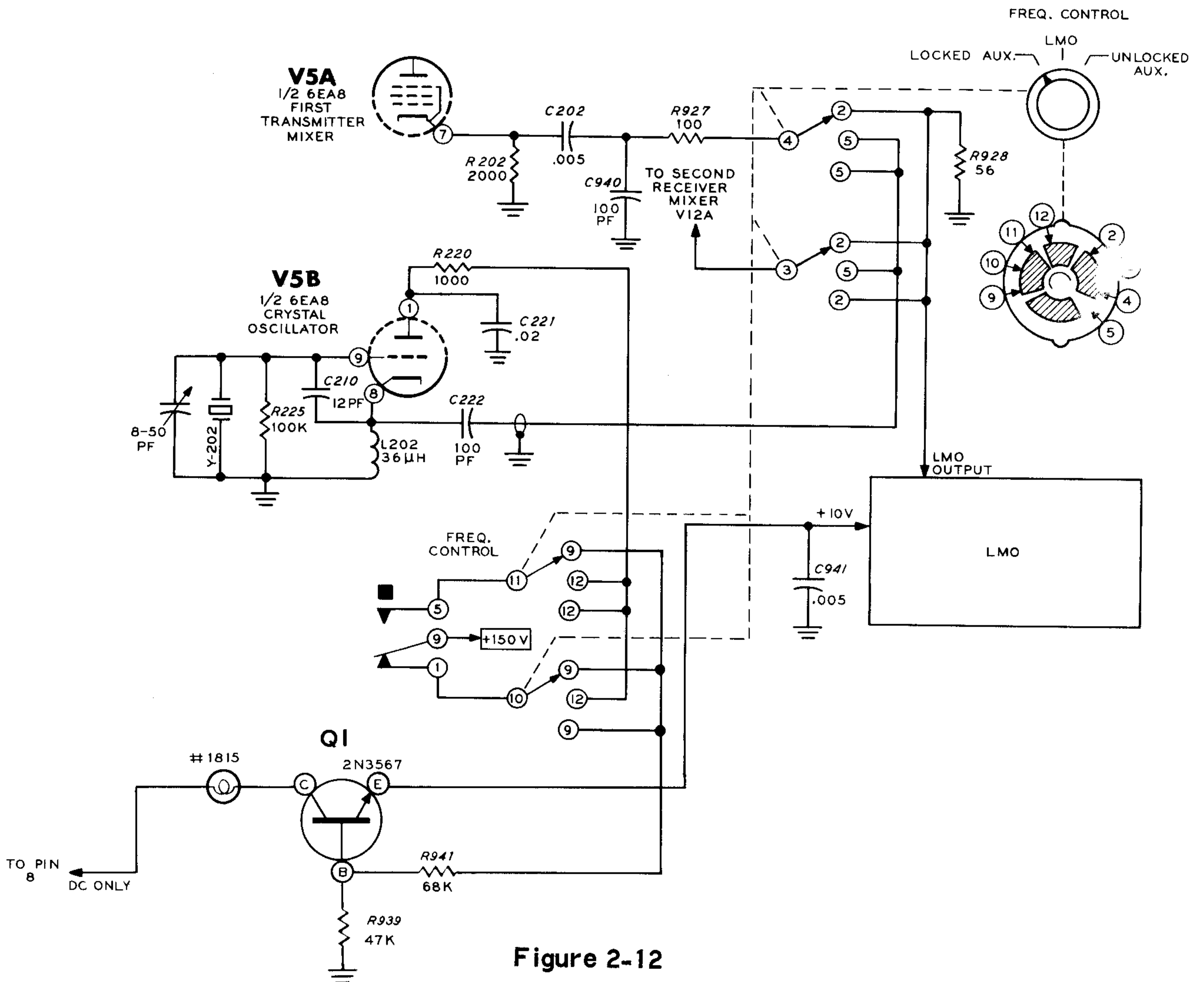

Figure 2-12

LMO Power Supply

During AC operation, 12.6 volts from the AC filament supply is rectified by diode D106 and filtered by capacitors C941, C942, and resistor R936. This voltage is then dropped to 10 volts by pilot lamp PL1 and regulated by zener diode D907. During mobile operation, a jumper wire connects pins 6 and 8 of the 11-pin power socket. This applies 12.6 volts DC directly to pilot lamp PL1 and by-passes diode D106.

Control transistor Q1 acts as a switch which turns the internal LMO on or off. When 150 volts DC is coupled through resistor R941 to the base of Q1, the internal LMO is turned on. When the Freq Control is turned to either AUX position, the 150 volts DC is applied either to the auxiliary oscillator or to the switching transistor as needed.

LMO

The LMO is a sealed unit containing a capacity-tuned silicon transistor oscillator and a transistor bandpass amplifier. (Since internal circuitry may vary due to temperature compensation, a circuit diagram of this circuit is not included.) The tuning capacitor is factory-adjusted to provide a linear frequency change with dial rotation, giving 100 kHz change per turn of the shaft between 5 and 5.5 MHz.

To provide the same dial reading in both USB and LSB, the LMO frequency must be shifted 2.8 kHz by the MODE switch. When a negative voltage is applied to the shift bias terminal (in LSB), it causes a switching diode to conduct, changing inductance in the oscillator circuit and causing a 2.8 kHz frequency change in the LMO. A positive voltage (in USB and CW) will open the diode switch, shifting the frequency to the correct operating point for USB and CW operation. This operating point can be adjusted by the sideband shift adjustment on top of the LMO.

The FSK terminal is connected to a voltage-variable capacitor in the LMO, and is not used in this Transceiver. Grounding this terminal through a resistance that is variable from zero to one megohm will change the frequency up to approximately 1000 Hz. See "RTTY Operation" on Page 116.

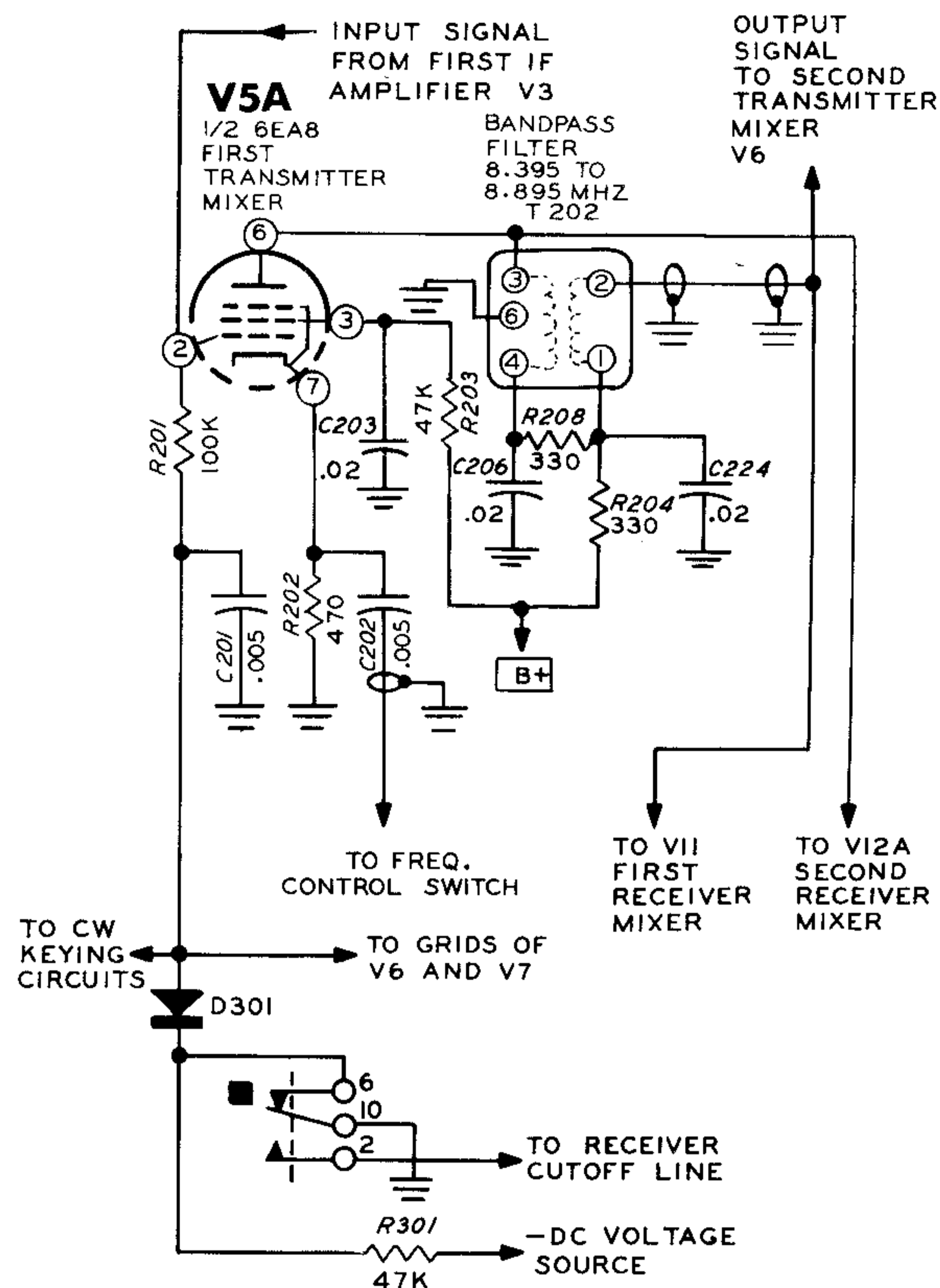

Figure 2-13

First Transmitter Mixer (Figure 2-13)

The 3.395 MHz IF signal at the grid, and the 5.105 MHz LMO signal (or crystal oscillator signal) at the cathode, are mixed in first transmitter mixer tube V5A to produce sum and difference frequencies. The 8.5 MHz sum of these two signals is coupled from the plate of V5A through Bandpass filter T202 to second transmitter mixer V6.

The Bandpass filter T202 is tuned to pass only those signal frequencies between 8.395 and 8.895 MHz; all other frequencies are attenuated. Only the 8.5 MHz sum of the IF and LMO signals falls within this frequency range, so it only is passed on to the second mixer.

First transmitter mixer V5A, second transmitter mixer V6, and driver V7 are cut off during the receive mode of operation by a negative voltage that is applied to their grids through diode D301 and resistor R301. This negative voltage is removed for the transmit mode by contacts 6 and 10 of relay RL2, which cause the cathode side of diode D301 to be grounded.

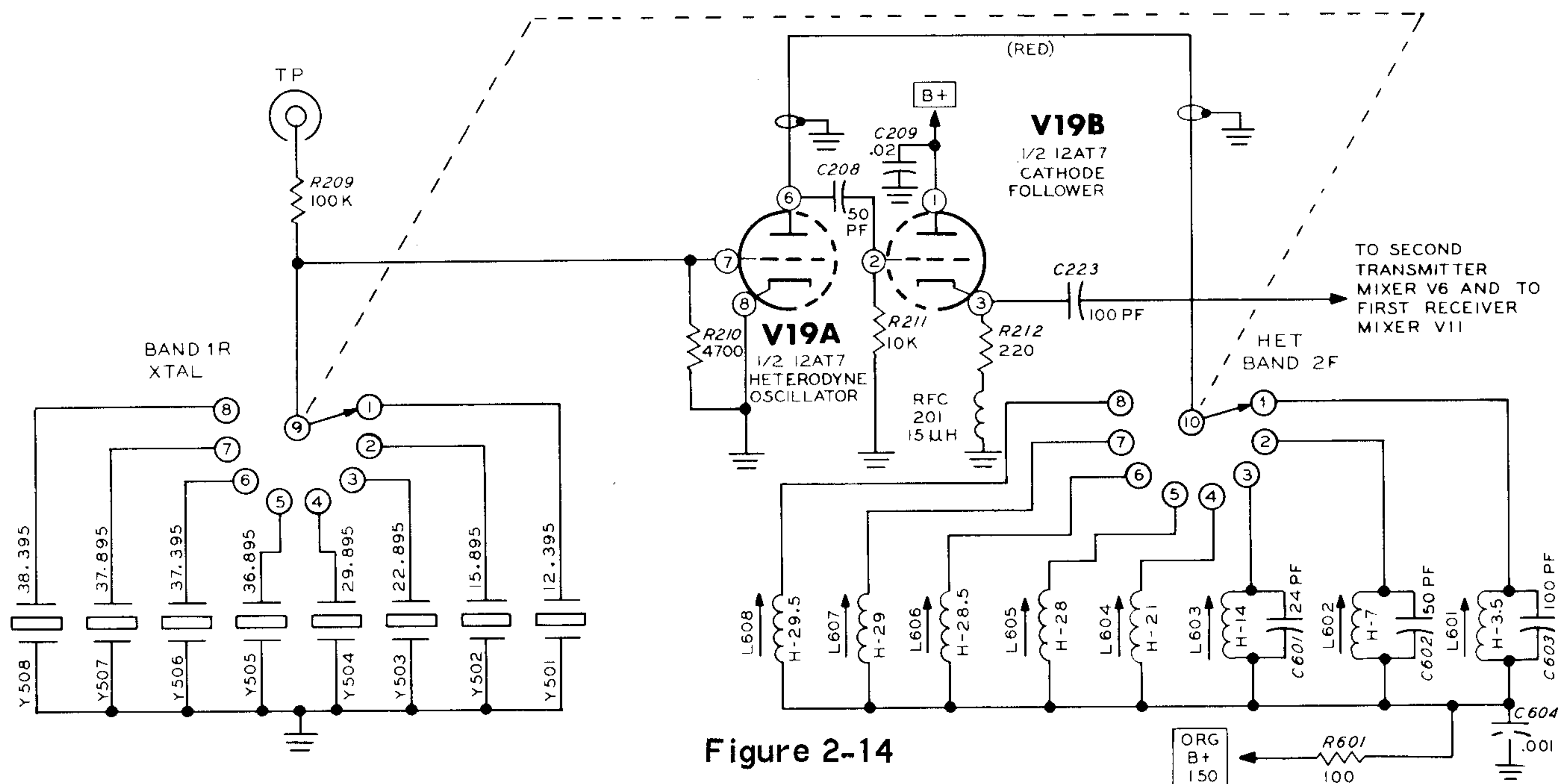

Figure 2-14

Heterodyne Oscillator and Cathode Follower (Figure 2-14)

Heterodyne Oscillator V19A operates as a tuned-plate crystal oscillator. The proper plate coil for each band, L601 through L608, is selected by wafer 2F on the Band switch. The output signal from the plate of the oscillator is coupled through cathode follower V19B to the cathode of second transmitter mixer V6 and to the cathode of first receiver mixer V11. The correct oscillator crystal for each band is selected by wafer 1R of the Band switch. The crystals below 20 MHz are fundamental cuts, and the higher frequency crystals operate on their third overtones. The grid voltage of V19A can be metered at TP to check oscillator activity.

Second Transmitter Mixer (Figure 2-15)

The 8.5 MHz signal from the first transmitter mixer and bandpass filter is coupled to the grid of second mixer tube V6. The 12.395 MHz output from the heterodyne oscillator is coupled to the cathode of V6. These signals are mixed in V6 to produce the operating frequency.

The frequency of the tuned plate circuit of second mixer V6 is the operating frequency. All other frequencies are shorted to ground. In this instance, the difference between the 8.5 MHz input frequency and the 12.395 MHz heterodyne oscillator frequency results in a second mixer output frequency of 3.895 MHz. This output signal is coupled to the grid of driver stage V7.

The 3.5 MHz plate tuning coil, L701, is connected across the plate tuned circuit on all bands, along with the fixed and variable tuning capacitors. Band switch wafer 3F connects the correct amount of inductance in parallel with L701 to tune each band, except the 3.5 MHz (80 meter) band, which uses coil L701 only.

Tuning capacitor C421B is connected across the tuned circuit on all bands. Tuning capacitor C421A is connected in parallel with C421B on the 80 meter band only, by Band switch wafer 3R.

The plate tank circuit of V6 is used in the receive mode as the plate circuit of V10, RF amplifier. Due to Miller effect, additional capacity is required when receiving to permit the driver preselector to peak at the same dial setting in both transmit and receive modes.

A negative voltage is always applied to the anode of D909 from the Bias Adjust control through resistor R954. When receiving, a higher positive voltage is applied to the anode of D909 from the screen circuit of V11 through resistor R955. As its anode is now positive, the diode conducts and acts as a closed switch to supply a ground to C955. This action places the capacitor in parallel with C421B and adds capacity to the plate tuned circuit.

In the transmit mode, the positive voltage is removed by the opening of contacts 3 and 11 of RL2. The remaining negative voltage prevents D909 from conducting and it consequently acts as an open switch, removing the ground from C955. The capacitance of C955 is therefore removed from the plate circuit of V6.

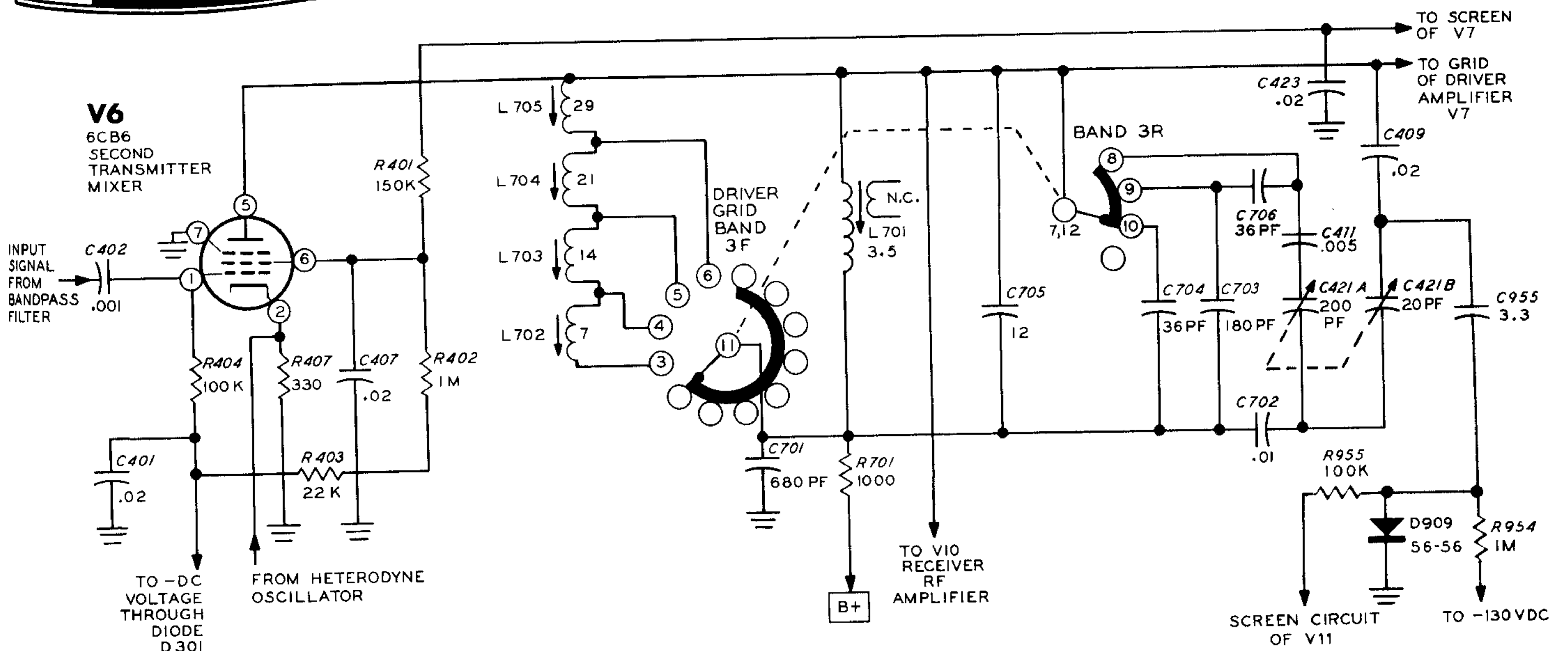

Figure 2-15

Driver (Figure 2-16)

Driver stage V7 amplifies the 3.895 MHz signal from second transmitter mixer V6 to a level that is sufficient to drive the final amplifiers.

The 3.5 MHz plate tuning coil, L801, is connected across the plate tuned circuit on all bands along with the fixed and variable tuning capacitors. A secondary (link) winding on L801 is used in the receive mode of operation to couple the received signal into the Transceiver.

Band switch wafer 4F connects the correct amount of inductance in parallel with L801 to

tune each band, except the 3.5 MHz (80 meter) band, which uses coil L801 only. Band switch wafer 4R connects additional capacitance in parallel with tuning capacitor C422B for the 80 meter (3.5 MHz), 40 meter (7 MHz), and 20 meter (14 MHz) bands.

Neutralization of V7 is accomplished by feeding a portion of the plate signal back to the grid through a "neutralizing wire" capacitor to the plate tuned circuit of the second transmitter mixer.

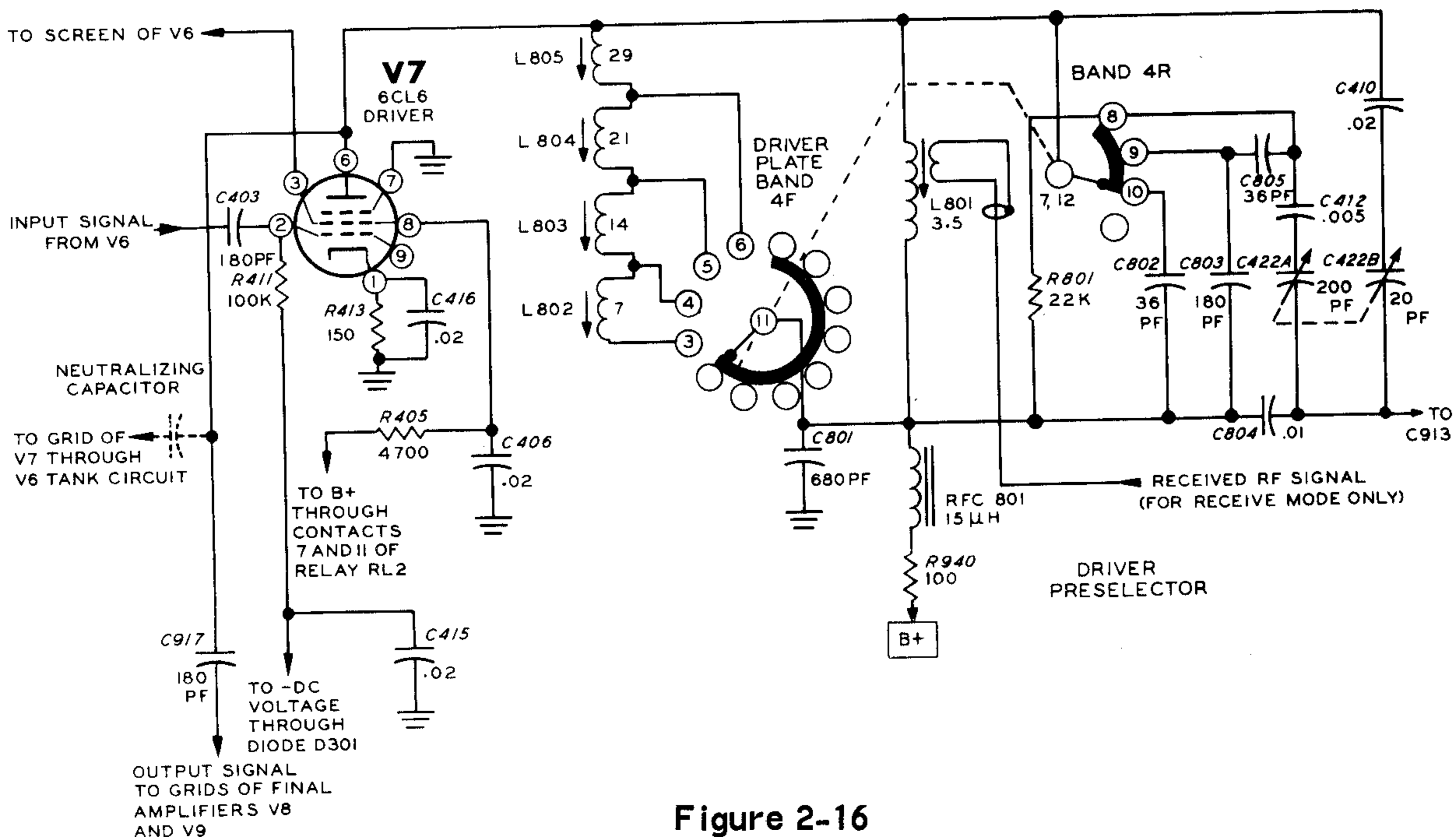

Figure 2-16

Final Amplifiers (Figure 2-17)

Final amplifier tubes V8 and V9 are connected in parallel and function as class AB1 linear amplifiers. A fixed negative bias is applied to the grids of these tubes through resistor R916 and choke L903. This bias limits zero-signal plate current. B+ is removed from the screen grids under receive conditions, by lugs 7 and 11 of relay RL2 to reduce the plate current to zero and cut off the tubes. RF driving voltage is developed across RF choke L903. Plate voltage is shunt fed through RF choke L901.

For the LSB and USB modes of operation, the peak driving voltage is controlled by the Microphone level control (in the grid circuit of V1B) and the limiting action of the ALC (automatic level control) voltage. This ALC voltage is fed back to isolation amplifier V2 and IF amplifier V3.

The output signal from V8 and V9 is coupled through RF parasitic chokes L904 and L902 and through capacitor C915 to the final tuning capacitor C925 and plate tank coils L905 and L906. The parasitic chokes eliminate any tendency toward VHF parasitic oscillation.

Wafer 5R of the Band switch connects the proper portion of the plate tank coil in the circuit for each band by shorting out the unused section. Wafer 5R also selects the proper combination of final tank tuning and loading capacitors for each band.

Neutralization of the final amplifier is accomplished by feeding a portion of the plate signal back to the grid through neutralizing capacitors C913 and C914, and across C801 in a bridge circuit.

The output signal from the final tank coil is coupled through lugs 8 and 12 of relay RL1 to the RF Out socket. The driver output jack is for use with transverters (transmitting converters).

ALC Circuit (Figure 2-17)

The ALC (automatic level control) bias voltage is developed from a small portion of the signal in the final amplifier stage. This signal is then rectified, filtered, and fed back to the preceding stages to adjust their gain automatically, as needed. ALC voltage assures maximum transmitter output without overloading.

The ALC voltage for this Transceiver is developed in the Heath TALC™ (Triple Action Level Control) circuit. This circuit keeps the transmitter from overloading, without causing the voice peaks to be flat-topped, by compressing the speech waveform. The triple action of this circuit is described below in paragraphs 1, 2, and 3.

1. Any peak voltages at the grids of final tubes V8 and V9 that drive the grids positive into grid current will develop bursts of voltage across resistor R916. This forms an audio-frequency AC that is coupled through capacitor C911 to voltage doubler rectifiers D902 and D903. The rectified negative output voltage goes to the ALC line.
2. The variations that occur in the final amplifier screen supply voltage on speech peaks produce a varying voltage which is coupled through capacitor C908 to rectifiers D902 and D903. This second voltage source produces additional ALC voltage.
3. The ALC voltage that is obtained from an external linear power amplifier can be applied through the ALC connector to rectifiers D902 and D903. With proper conditions, this source should have predominate control, thus holding down the drive in the Transceiver for best operation.

The rectified voltage from diode D903 is applied to an RC network consisting of resistors R914 and R915, and capacitors C931 and C932. This network filters the DC bias voltage, and allows it to build up quickly and decay slowly.

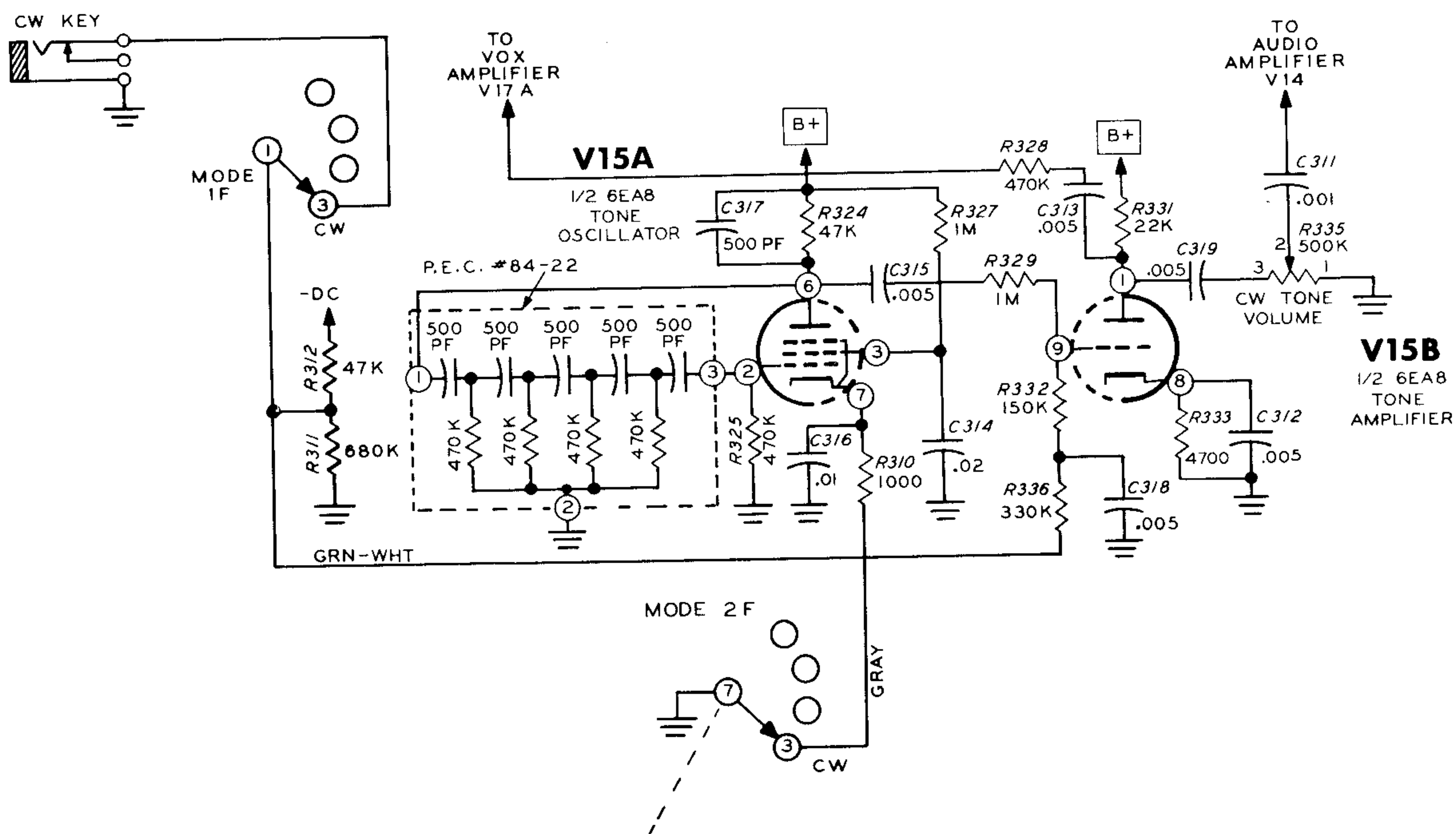

Figure 2-18

From the RC filter network, the ALC voltage is applied to the grid of isolation amplifier V2, where it limits the output, thus reducing the drive available to the final amplifiers. The ALC voltage is also coupled through lugs 8 and 12 of relay RL2 to IF amplifier V3.

ALC voltage is not developed for CW operation. Adjustable bias from the Mic/CW Level control is used instead.

Tone Oscillator and Amplifier (Figure 2-18)

The tone oscillator circuit, V15, generates a 1000 Hz audio signal that is used for CW operation only. This tone is inserted into the VOX circuit to turn on the transmitter. It is also coupled to the receiver audio amplifier so the operator can monitor his transmitted signal.

Tone oscillator V15A is turned on when its cathode is connected to ground through wafer 2F of the Mode switch. The output frequency of V15A is determined by the phase-shift network (P.E.C. #84-22) in its grid circuit. From the plate of V15A, the 1000 Hz tone is coupled through capacitor C315 and resistor R329 to the grid of tone amplifier V15B.

Tone amplifier V15B is normally cut off by a negative bias that is applied to its grid from the junction of resistors R311 and R312. When the CW key is closed, this cut-off bias is removed (resistor R311 is shorted out through Mode switch wafer 1F and the key), and V15B conducts.

From the plate of V15B, the 1000 cps tone is coupled to the CW Tone Volume control, and from there to audio amplifier V14B. The 1000 cps tone is also coupled through capacitor C313 and resistor R328 to the grid of VOX amplifier V17A, where it causes the transmitter to be turned on.

CW Operation

When the Mode switch is turned to the CW position, the following circuit changes occur:

1. Cathode follower V1B is cut off and the arm of VOX Sensitivity control is grounded so stray microphone signals do not reach the balanced modulator or VOX circuits.
2. CW crystal Y3 is connected to the grid of carrier oscillator V16B.
3. The balanced modulator circuit is unbalanced so it will produce an output signal (see Mode switch wafer 2F).
4. The transmitted CW signal will pass through either the Accessory CW Filter or the SSB Filter.
5. The drive to the final amplifiers is controlled by the CW section of the MIC/CW Level control, which adjusts the bias of isolation amplifier V2 and IF amplifier V3.
6. Cut off bias is applied to the grids of transmitter mixers V5A and V6, and to the grid of driver amplifier V7, through Mode switch wafer 1F and diode D904.
7. Tone oscillator V15A is turned on.

When the key is closed, the 1000 Hz tone signal is coupled to the VOX circuit, where it causes the relays to be switched to the transmit position. The relays stay in this position for a length of time that is determined by the setting of the VOX Delay control.

At the same time, the key shorts out the cut-off bias that is applied to the transmitter mixer stages and to the driver amplifier stage, allowing them to conduct and place the transmitter on the air.

The RF output signal from CW carrier oscillator V16B is coupled to the balanced modulator stage. The unbalanced condition of this stage causes the RF signal to be coupled through transformer T1 to isolation amplifier V2. From V2, the signal proceeds through the transmitter in the same manner as the LSB and USB signals.

Switching (Figure 2-19)

Figure 2-19 shows the position and assigns an identifying number to each of the relay sections on the main schematic. The numbers will be used in the following paragraphs to explain how each section is used.

1. This section applies B+ voltage to the correct half of carrier oscillator tube V16 in the Tune and CW positions of the Mode switch.
2. This section is connected to the power plug for external use with linear amplifiers and other devices. The contacts have a rating of 3 amperes at 117 VAC or 30 VDC.
3. These contacts apply B+ voltage to the screens of V2, V7, V8, and V9 in the transmit mode, and to the screen of V4, V10 and V11 in the receive mode of operation.
4. These contacts ground out the receiver cut-off bias in the receive mode. In the transmit mode they ground out the cut-off bias that is applied through diode D301 to transmitter stages V5A, V6, and V7.

RELAY POSITIONS

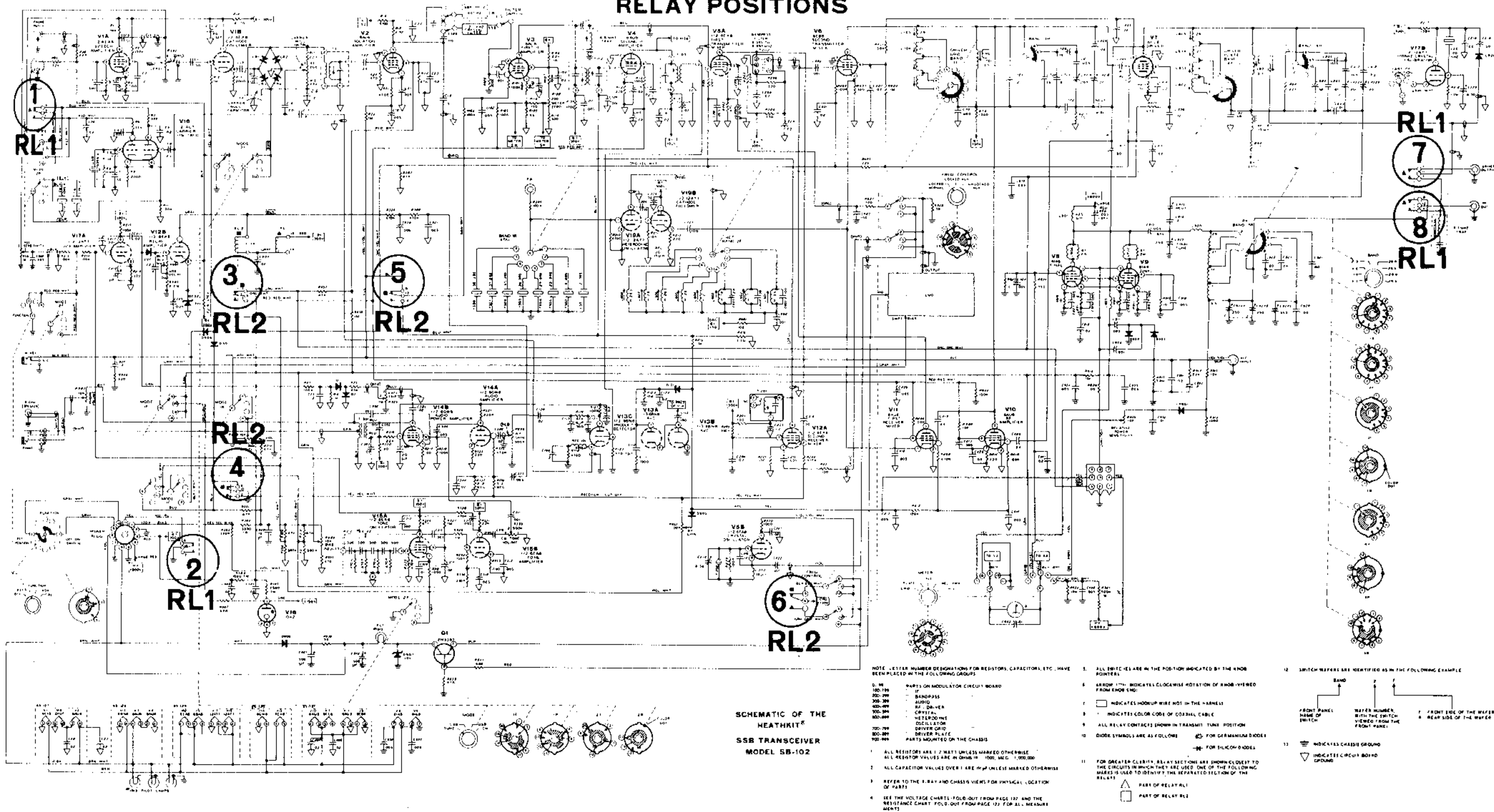

Figure 2-19

- 5. In the transmit mode, these contacts apply ALC voltage (or CW bias) to the grid of V3. In the receive mode they apply AVC voltage to V3.
- 6. This section applies +150 V B+ voltage through the Freq Control switch to either the LMO or crystal oscillator V5B.
- 7,8. These contacts switch the antenna between the receive and transmit circuits.

When the Transceiver is in the transmit mode, a large negative bias (approximately -90 volts) is applied through the RF Gain control and diode D905 to the grids of RF amplifier V10, and first receiver mixer V11. Smaller amounts of negative bias are also applied to second receiver mixer V12A, second IF amplifier V4, and audio amplifier V14A. The large bias is necessary at V10 to keep the transmitter signal at the

driver plate from causing V10 to conduct on large voltage peaks. (If this happens, spikes will appear at the peaks of the envelope on the transmitted signal.)

First audio amplifier V14B is cut off by the bias voltage to quiet the receiver audio stages when LSB or USB signals are being transmitted. A negative pulse is also applied to the grid of V14A to cut it off before the relay contacts close. This is done so the switching transients, which cause a "popping" sound, will not be heard in the speaker.

The negative pulse that is applied to V14B is formed by the sudden voltage change that occurs at the plate of relay amplifier V12B when that stage is turned on by the VOX circuit. This pulse is shaped by a network that consists of resistors R337, R338, R339, and R340 and capacitors C320, C321, C322, and C323.

BAND	RECEIVED SIGNAL FREQUENCY	HETERODYNE OSCILLATOR FREQUENCY (CRYSTAL)	SIGNAL FREQUENCY AT BANDPASS FILTER (BETWEEN 8.395 AND 8.895)	2ND RECEIVER MIXER, CRYSTAL FILTER AND IF FREQUENCIES	LMO FREQUENCY (BETWEEN 5 AND 5.5)
3.5 to 4	3.895	12.395	8.5	3.395	5.105
7 to 7.5	7.2	15.895	8.695	3.395	5.3
14 to 14.5	14.2	22.895	8.695	3.395	5.3
21 to 21.5	21.3	29.895	8.595	3.395	5.2
28 to 28.5	28.1	36.895	8.795	3.395	5.4
28.5 to 29	28.7	37.395	8.695	3.395	5.3
29 to 29.5	29.2	37.895	8.695	3.395	5.3
29.5 to 30	29.6	38.395	8.795	3.395	5.4

All frequencies in MHz.

Figure 2-20

RECEIVER CIRCUITS

NOTE: Figure 2-20 shows the various frequencies that will be found throughout the Transceiver on the different bands. A received signal (lower sideband) frequency of 3.895 MHz, shown on the first line of the chart, will be used when tracing through the receiver circuits. The other associated frequencies used in this Description are also shown on the first line. Mode is in LSB, relays are in receive position.

RF Amplifier (Figure 2-21, fold-out from Page 148)

The 3.895 MHz input signal from the antenna is coupled through lugs 3 and 11 of the antenna relay (RL1) to the link winding of coil L801. The secondary of L801, part of the Driver Preselector capacitor, and the other components in the driver plate tank circuit, are also used as the input tuned circuit for RF amplifier V10. From L801, the signal is coupled through capacitor C408 to the grid of V10.

The received signal is amplified in V10, and then coupled through capacitor C419 to first receiver mixer V11. The plate tuned circuit of V10 consists of coil L701, part of the Driver Preselector capacitor, and the other components of the second transmitter mixer plate tank circuit.

The gain of RF amplifier V10 and first receiver mixer V11 are controlled by the AVC voltage, and an adjustable negative bias that is coupled to their grids from the RF Gain control.

First and Second Receiver Mixers (Figure 2-22)

The amplified 3.895 MHz signal from RF amplifier V10 is coupled through capacitor C419 to the grid of V11, the first receiver mixer. At the same time, a crystal controlled 12.395 MHz signal is coupled to the cathode of V11 from V19B, the heterodyne oscillator cathode follower. These two signals are then mixed together in V11 and coupled with the sum and difference frequencies to the bandpass filter.

The bandpass filter, which passes only the frequencies between 8.395 and 8.895 MHz, allows the 8.5 MHz difference frequency to pass on from V11 to the grid of second mixer tube V12A.

A 5.105 MHz signal is coupled from either the LMO or crystal oscillator V5B, through the Freq Control switch to the cathode of V12A. The 8.5 MHz signal at the grid and the 5.105 MHz signal at the cathode are then mixed together in tube V12A and the 3.395 MHz difference frequency is coupled through crystal filter FL1 to the IF amplifiers.

The Filter switch selects either crystal filter FL1 for SSB use or FL2 for CW use. Crystal filter FL1 sets the IF bandwidth at just 2.1 kHz wide (see Figure 2-11 on Page 141). This narrow, steep sided passband permits good selectivity for SSB reception in crowded amateur bands. Crystal filter FL2 can be switched in for CW reception. FL2 sets the IF bandwidth at just 400 Hz wide. This narrow bandwidth is good for CW reception only.

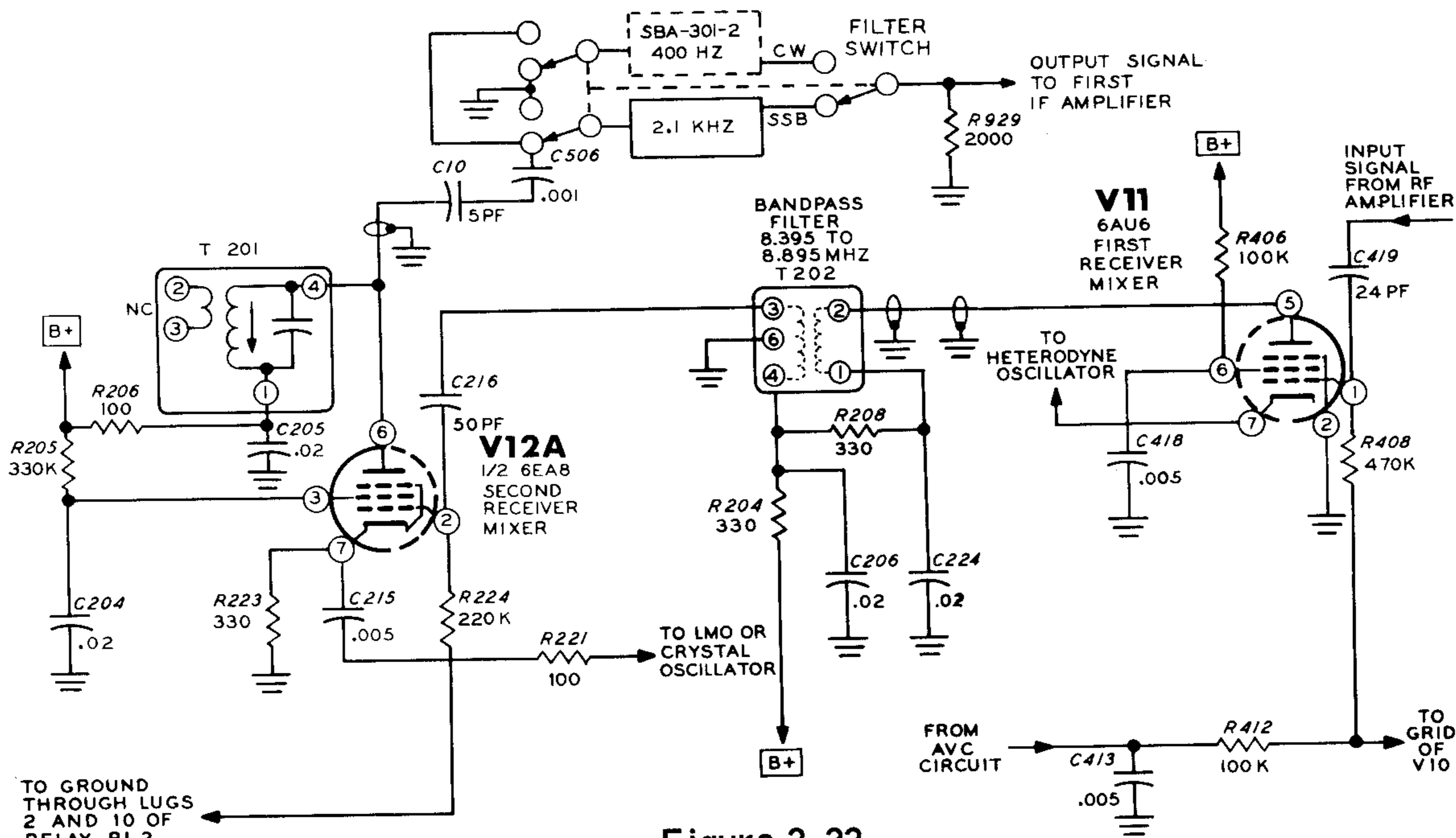

Figure 2-22

IF Amplifiers (Figure 2-23)

The signal from crystal filter FL1 is coupled through capacitor C101 to first IF amplifier V3. The amplified signal from V3 is coupled to two places: to the grid of V5A, which is cut off in receive operation; and to second IF amplifier V4 through IF transformer T102.

The amplified signal from V4 is coupled through

IF transformer T103 to the product detector, V13C. The same signal is also coupled through capacitor C112 to the plate of AVC rectifier V13B. Supply voltage for the screen of IF amplifier V4 is switched through lugs 3 and 11 of relay RL2.

AVC voltage is supplied to the grid of V4 by the AVC line. AVC voltage is switched to the grid of V3 through lugs 4 and 12 of relay RL2.

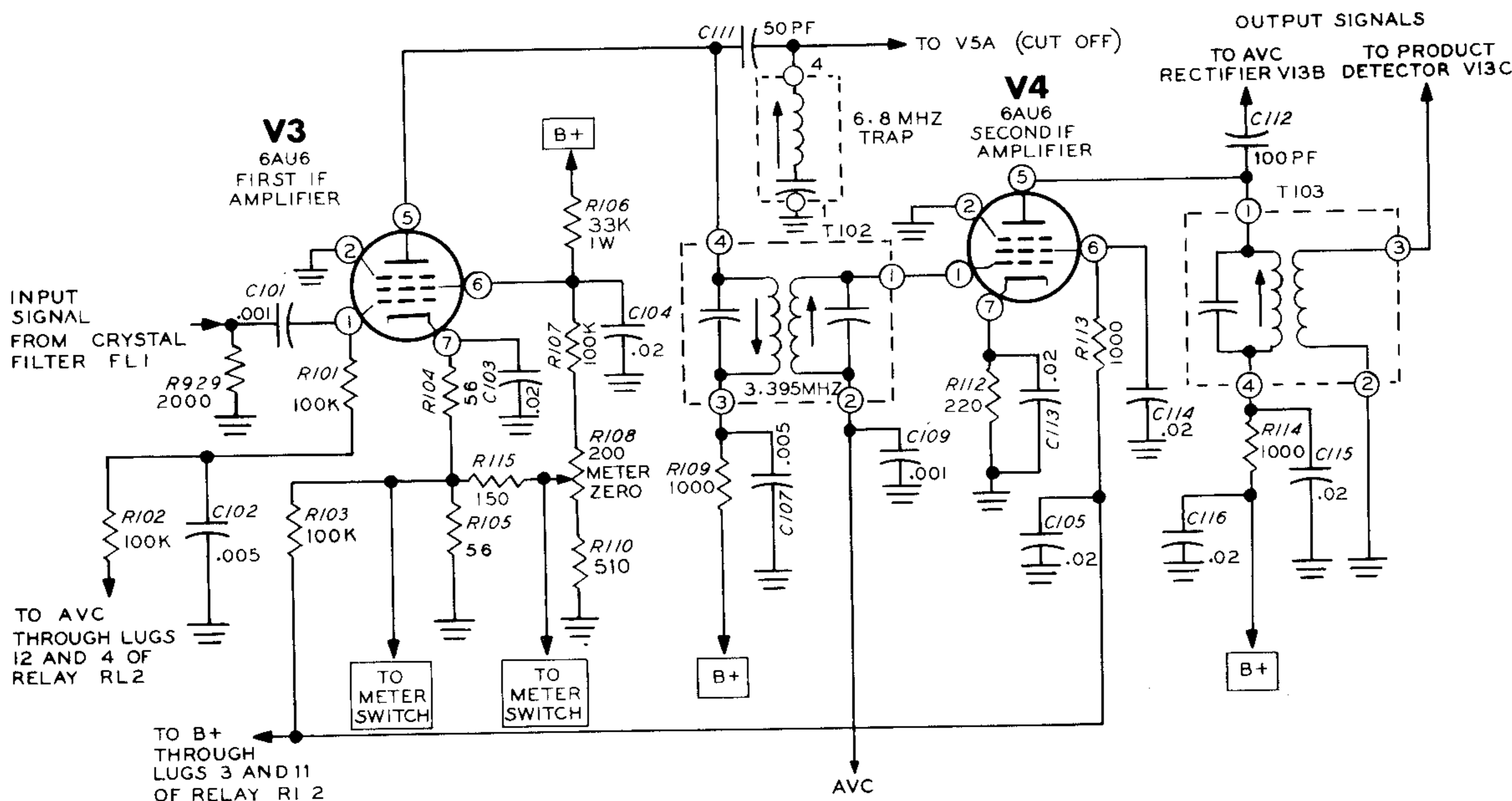

Figure 2-23

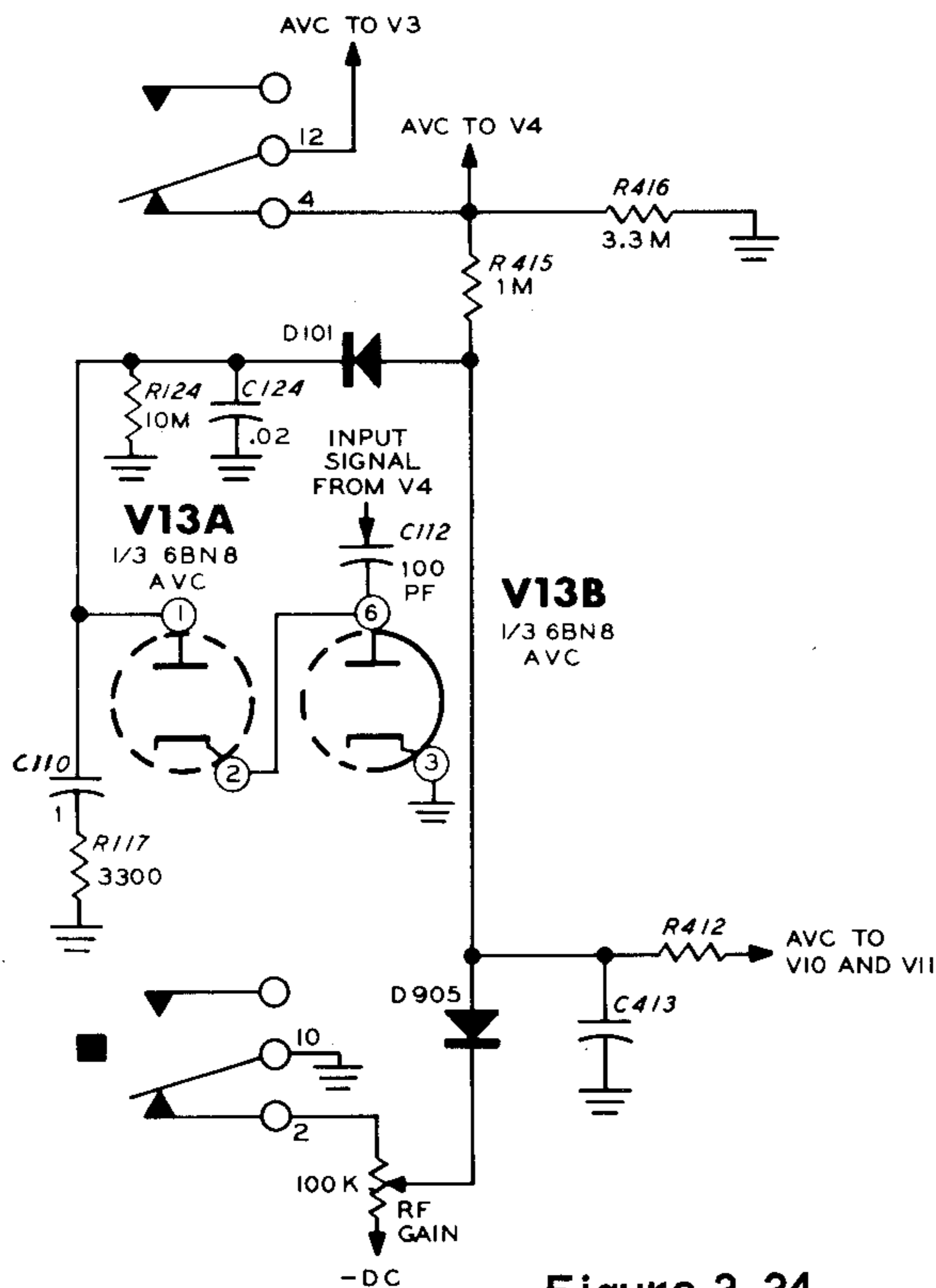

Figure 2-24

AVC Circuit (Figure 2-24)

The negative bias at the control grids determines the amount of amplification that will be obtained from RF amplifier V10, first receiver mixer V11, and IF amplifiers V3 and V4. The DC bias for these stages comes from the following two sources: from the -DC voltage at the arm of the RF Gain control; and from the AVC voltage. These two voltage sources are connected to diodes D101 and D905, which act as a diode gate. This diode gate permits either voltage to control the gain (of V10, V11, etc.) without interacting with each other.

From this point, the bias voltage is coupled through resistor R412 to the grids of V10 and V11, and through resistor R415 to the grids of V3 and V4. Voltage divider resistors R415 and R416 cause only one half of the total bias voltage to be coupled to the grids of IF amplifiers V3 and V4.

AVC voltage is obtained by coupling part of the IF signal through capacitor C112 to AVC diodes V13A and V13B. These diodes produce a negative DC voltage at pin 1 of V13A that is proportional to the signal strength. This negative voltage is developed across resistors R124 and R117, and capacitors C110 and C124. Capacitor C124 charges quickly to the peak voltage so the AVC will respond quickly to keep large signals from being distorted in V3, V4, V10, and V11. Capacitor C110 charges more slowly, and causes the AVC voltage to be proportional to the average signal level of the received signal. This produces a fast-attack, slow-release AVC characteristic.

An incoming signal that produces a negative AVC voltage that is significantly higher than the bias voltage from the RF Gain control causes the gain of V10, V11, V3, and V4 to be reduced. This keeps the output of the RF and IF amplifier stages at a nearly constant level despite wide amplitude changes in the received signal.

Product Detector (Figure 2-25)

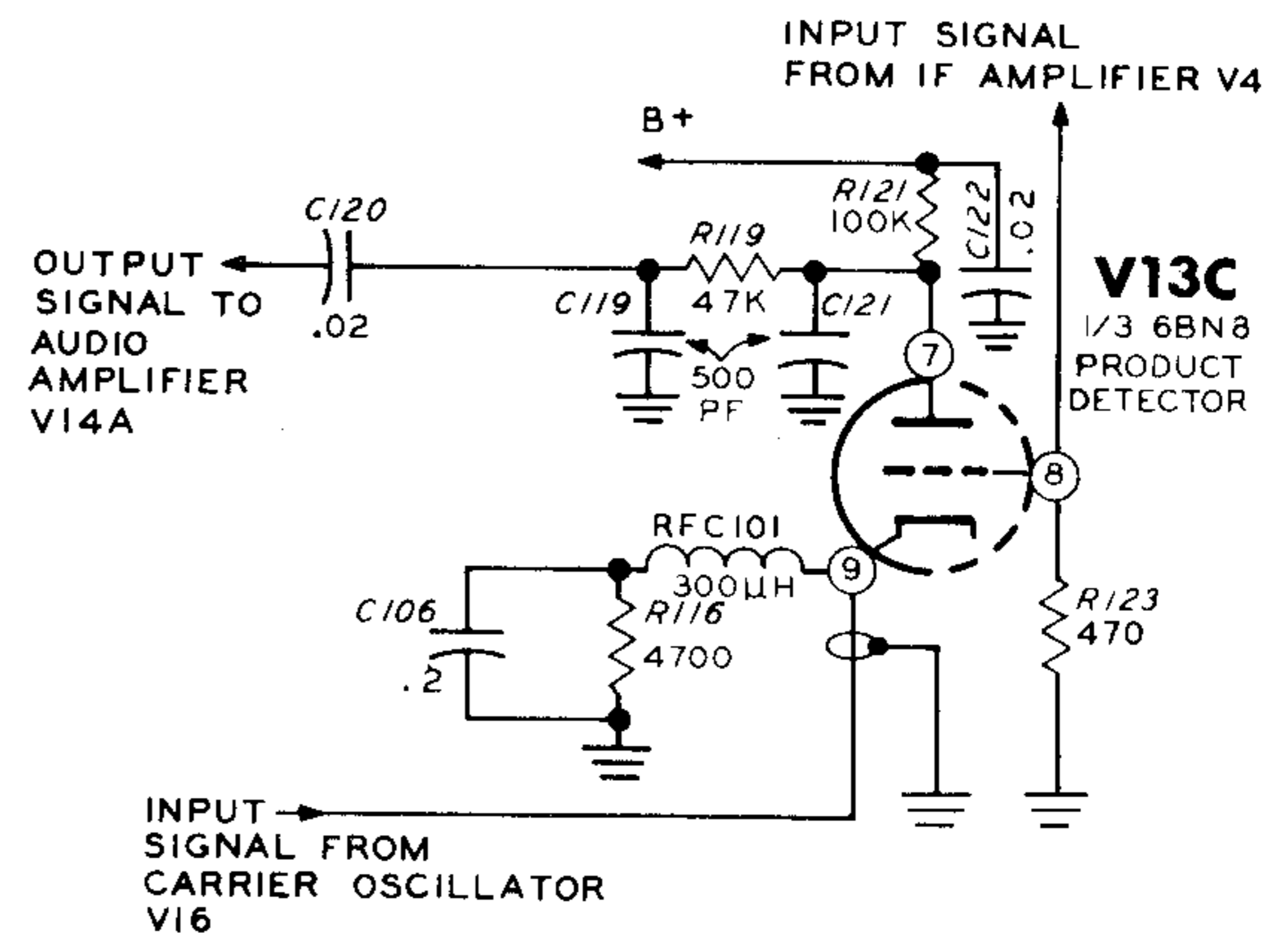

Figure 2-25

The 3.395 MHz signal from IF amplifier V4 is coupled to the grid of product detector tube V13C. At the same time, the signal from carrier oscillator V16 is fed to the cathode of V13C (3.3936 MHz for the lower sideband, or 3.3964 MHz for the upper sideband). These two signals are then mixed together in V13C, resulting in an audio output signal which is the

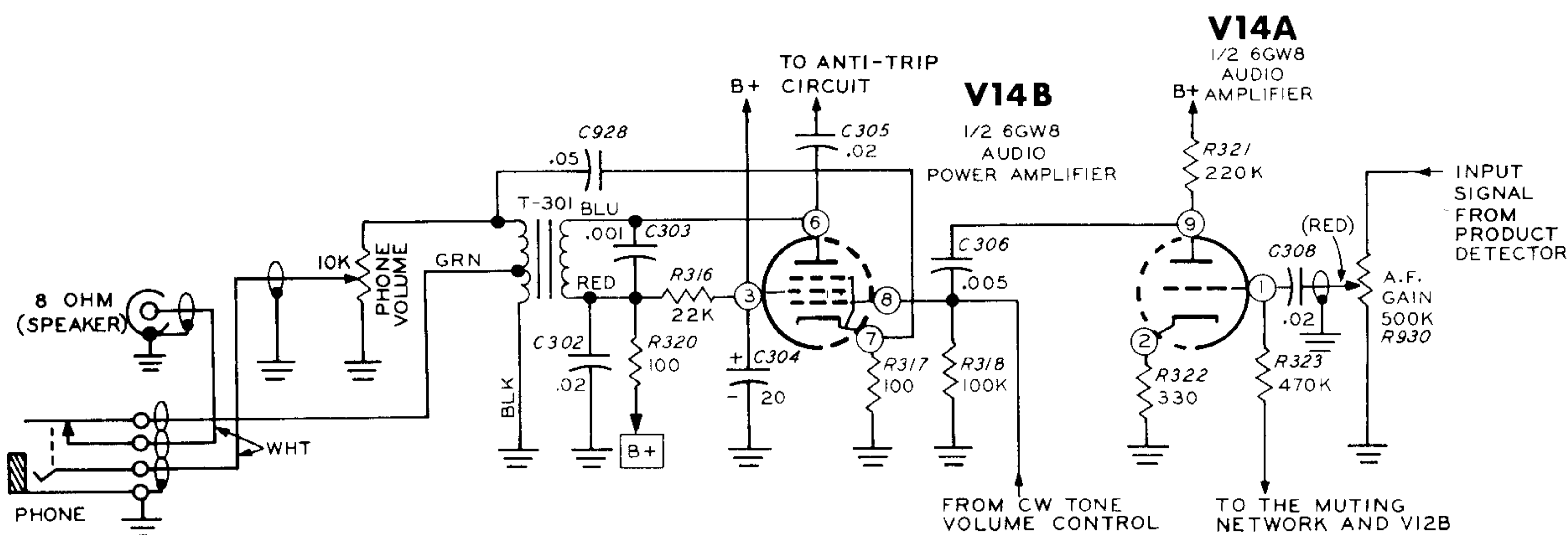

Figure 2-26

difference frequency between these two signals. Capacitors C119 and C121, and resistor R119 are connected in a filter network that bypasses any RF signal coming from V13C to ground, but permits the audio signal to pass through to audio amplifier V14A.

Audio And Power Amplifier (Figure 2-26)

The signal from the product detector is applied to the AF Gain control to determine the amount of signal that will be coupled through capacitor C308 to the grid of audio amplifier V14A. The audio signal is amplified in V14A and then coupled to power amplifier V14B. Tube V14B amplifies the signal further and supplies the audio power through output transformer T301 to the output connectors. Capacitor C928 couples a portion of the output back to the cathode of V14B as negative feedback for less distortion.

Two outputs are provided by the secondary of transformer T301: a headphone output, and an 8 Ω speaker output. Audio power to the 8 Ω speaker jack is rated at 2 watts maximum.

An audio signal is also supplied to the anti-trip network from the plate of V14B.

CRYSTAL CALIBRATOR (Figure 2-27)

Crystal calibrator stage V17B is connected as a Pierce crystal oscillator. When the Function switch is placed in the Calibrate position, the

cathode of V17B is grounded, and an accurate 100 kHz signal is connected through capacitor C218 and diode CR201 to the antenna input of the receiver. The harmonics of this signal are then used for dial calibration checks.

Calibrate Crystal capacitor C220 may be adjusted to set the crystal calibrator to exactly 100 kHz using some standard such as WWV.

The Calibrate position of the Function switch also connects the grid of VOX amplifier V17A to ground to avoid accidental energizing of the transmitter when using the crystal calibrator.

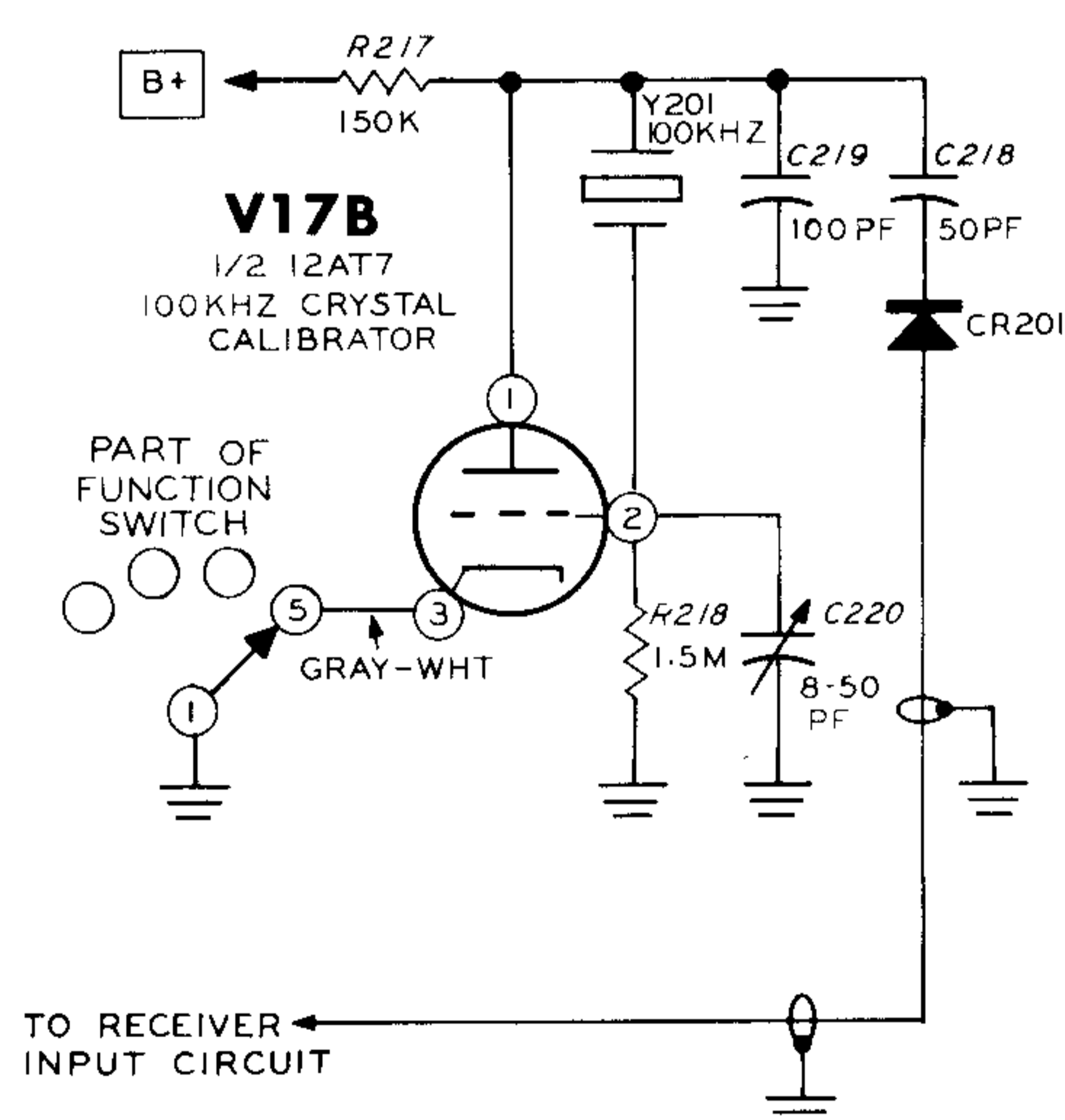

Figure 2-27

METERING CIRCUITS (Figure 2-28)

For the transmitting mode of operation, there are five different settings of the Meter switch: final Grid current, final Plate current, ALC voltage, Relative Power output, and High Voltage. In the ALC position, in the receive mode, the meter operates as an S-Meter.

To measure the grid current for final amplifiers V8 and V9, the meter is shunted across resistor R916 in the grid circuit of these tubes. The meter will then read from 0 to 1 mA of grid current.

To measure final amplifier plate current, the meter is connected between the cathodes of the finals and ground, in parallel with the cathode resistors. Plate current can then be read on the 0 to 500 mA range of the meter.

To measure ALC voltage, the meter is connected between the cathode and screen circuits of IF amplifier V3. The meter zero control is adjusted for zero current flow through the meter with no signal input. When V3 receives a signal, the resulting current fluctuations in the cathode are indicated on the meter. Since the ALC voltage at the grid controls the gain of V3, the cathode current of V3 gives a relative indication of the ALC voltage level.

For Relative Power measurements, a small portion of the transmitter output signal is developed across resistor R912, rectified by diode CR901, and filtered by capacitor C933. The resulting DC voltage, is then indicated by the meter. The Relative Power Sensitivity control allows the operator to set his full power output indication at a convenient meter reading.

The high voltage is brought down to a measurable level by a precision multiplier resistor, R921. 0-1000 volts can be read on the 0-10 scale of the meter. Resistor R922 keeps the open circuit voltage at a safe level when the Meter switch is in other positions.

When the Transceiver is in the receive condition, and the Meter switch is at ALC, the meter indicates the relative strength of the received signal in S-units. The circuit operates just as it does when it measures ALC voltage, except that the current in V3 is now controlled by the AVC voltage at the grid of V3.

The Meter Zero control is adjusted for a zero indication on the meter with the antenna disconnected and RF Gain control at the full clockwise position. The decrease in plate current (due to a larger AVC voltage) that occurs when a signal is received by tube V3 then appears as indications on the S-Meter.

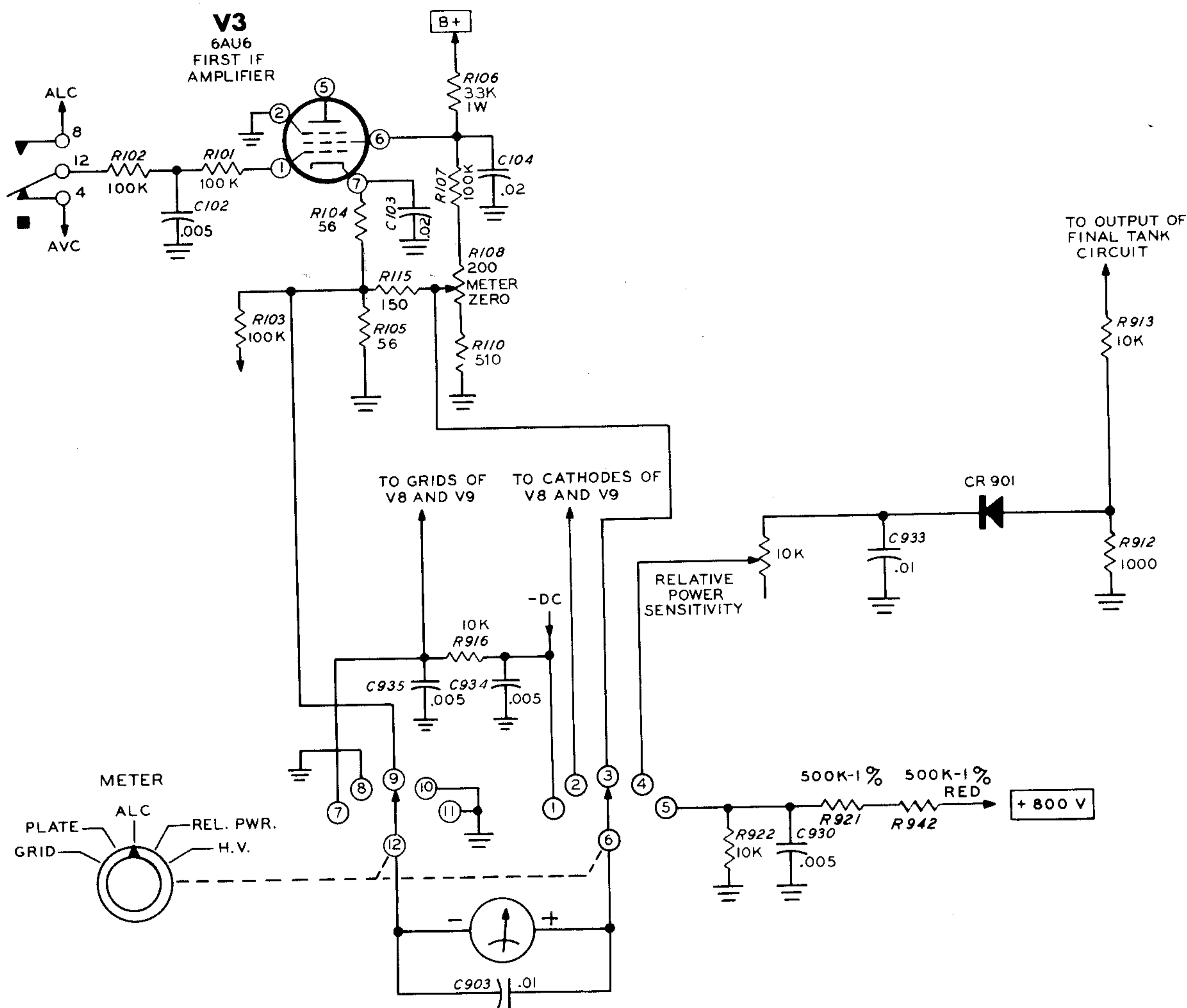
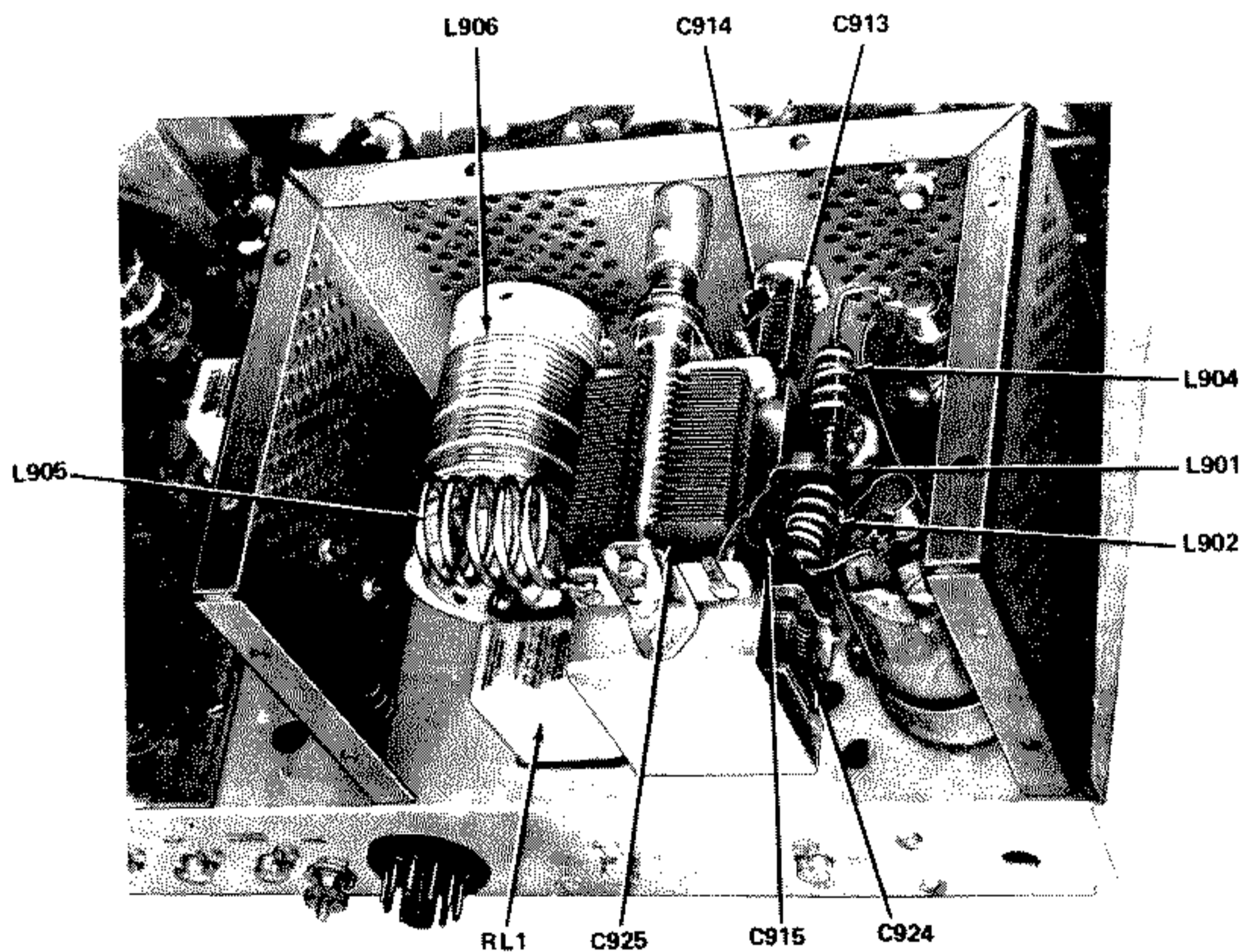
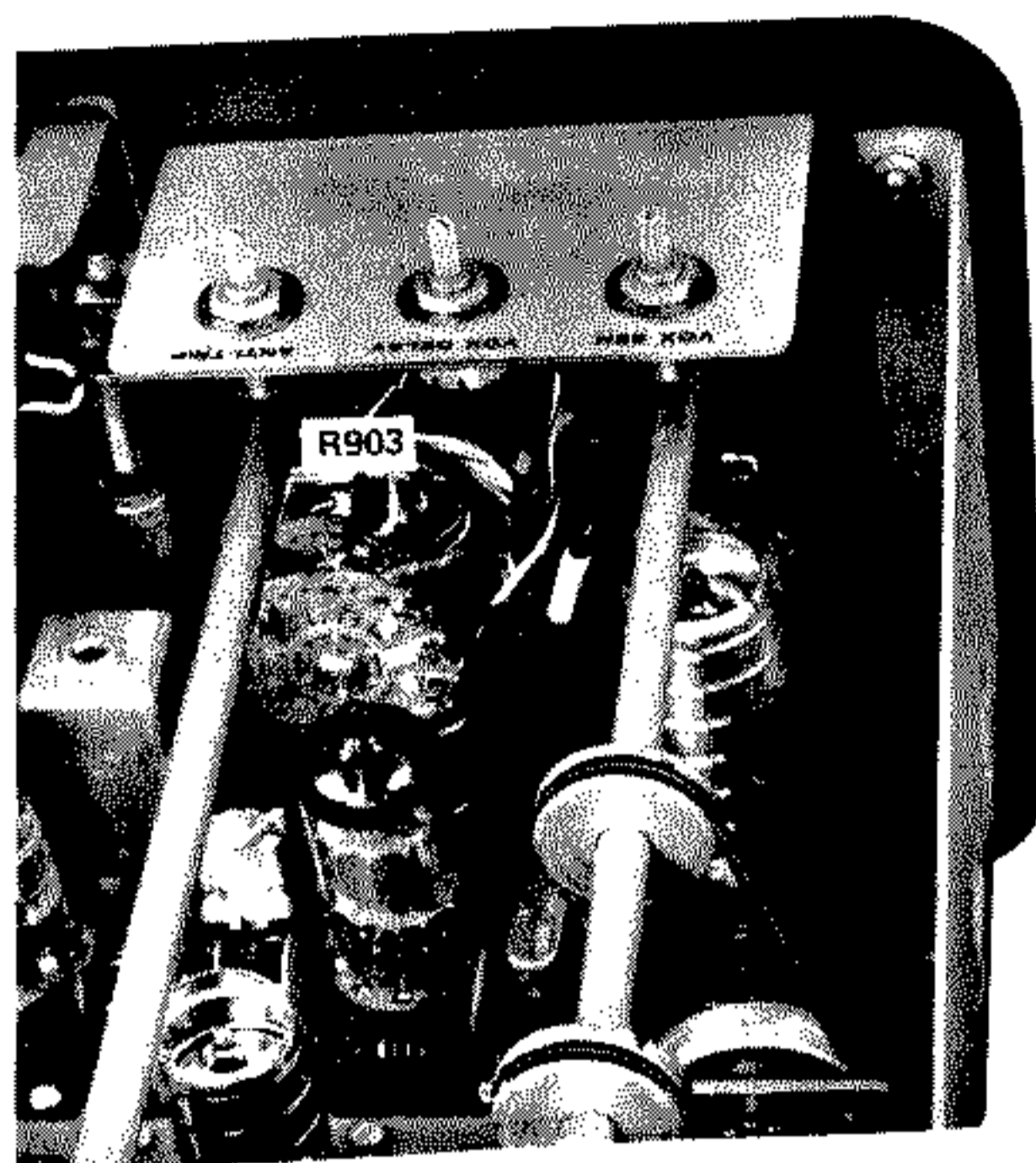
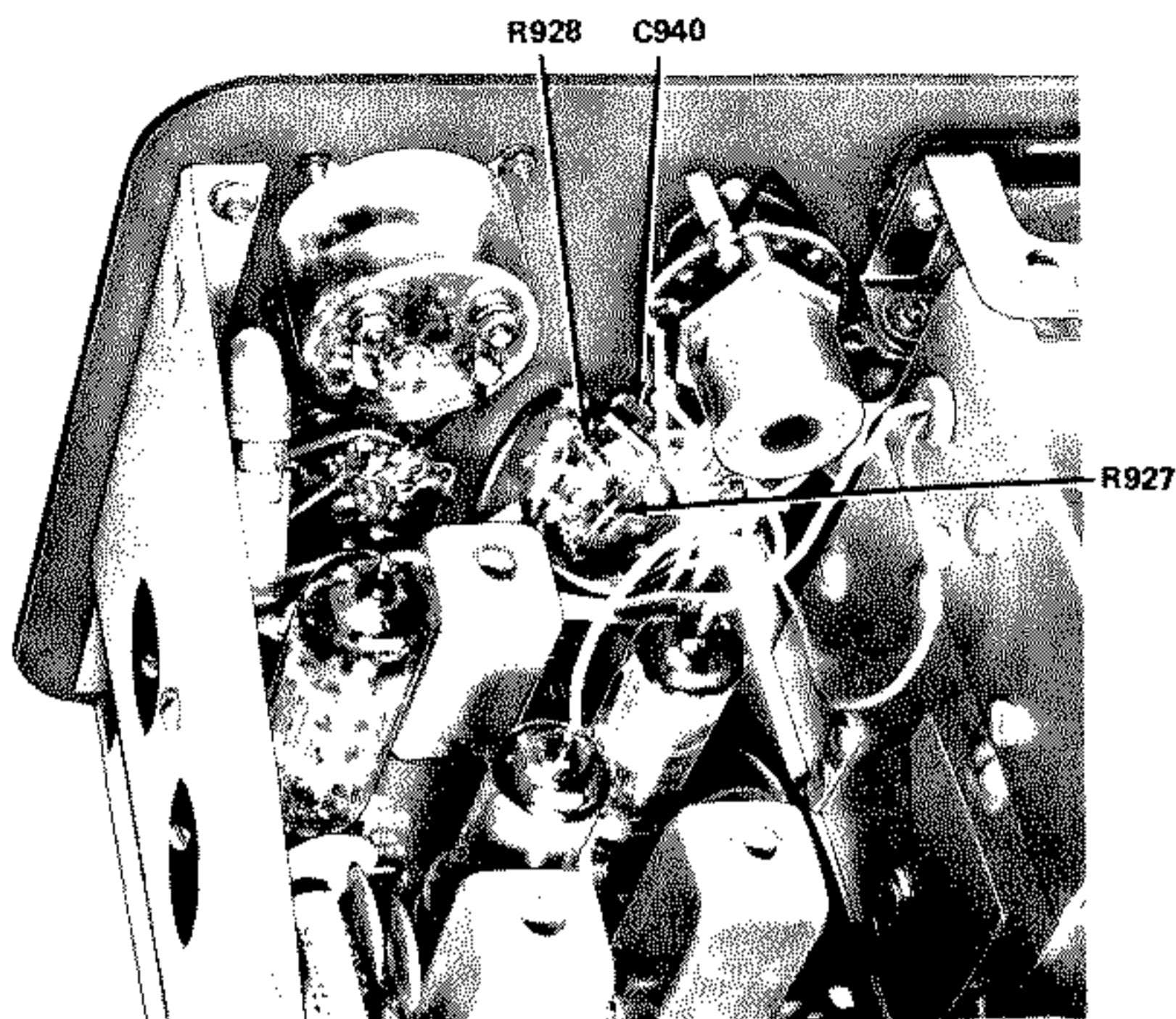
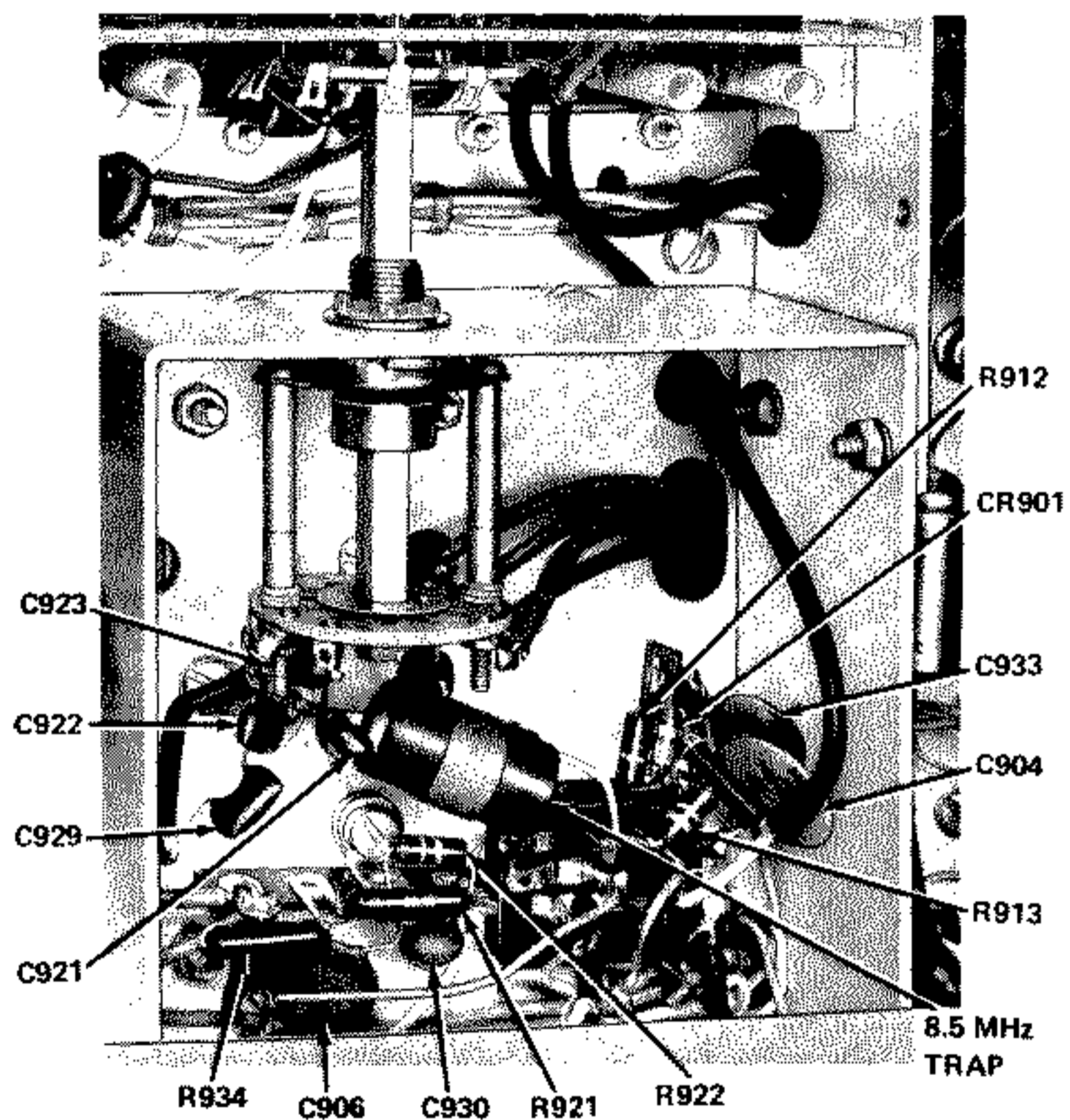
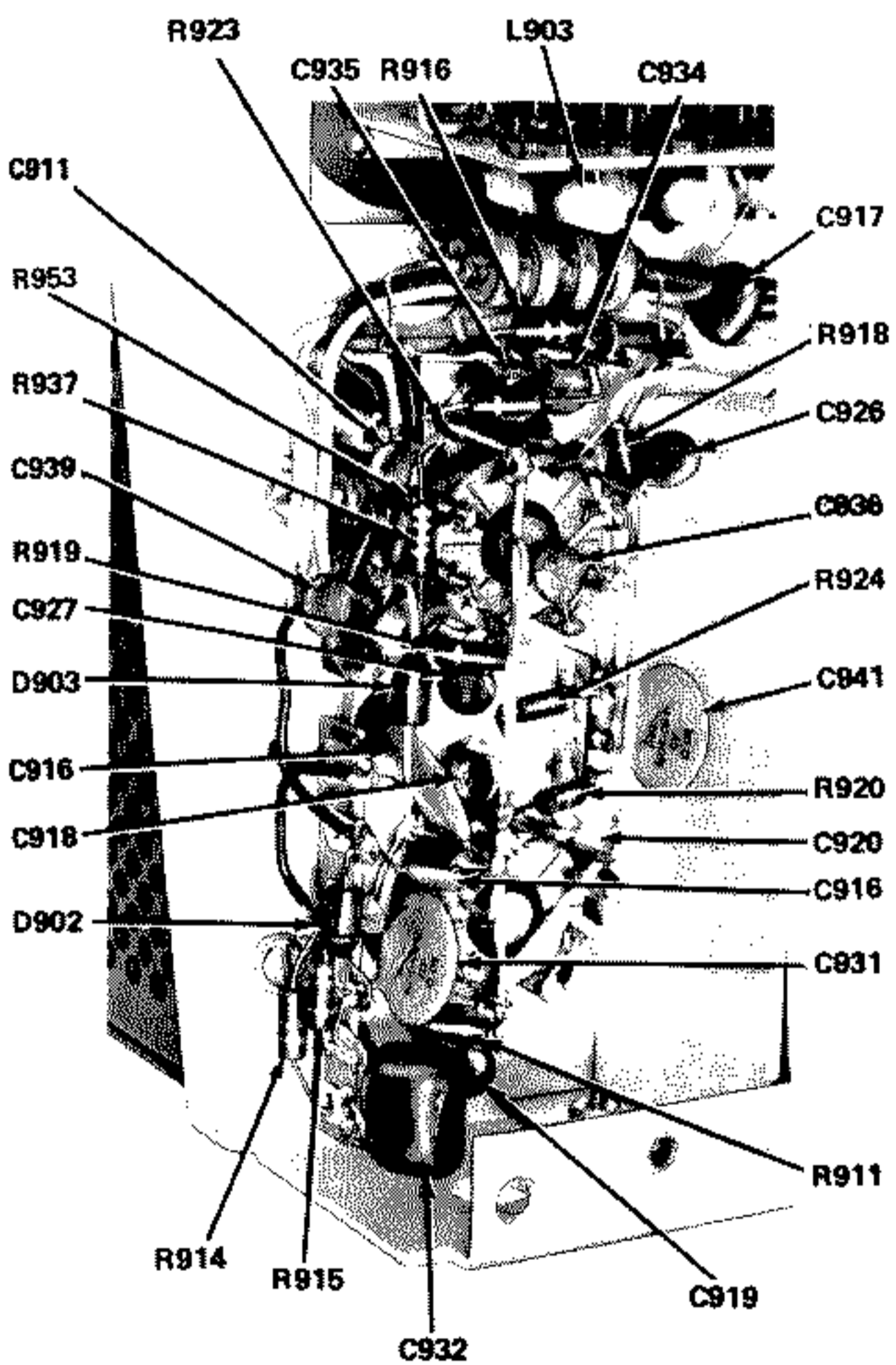
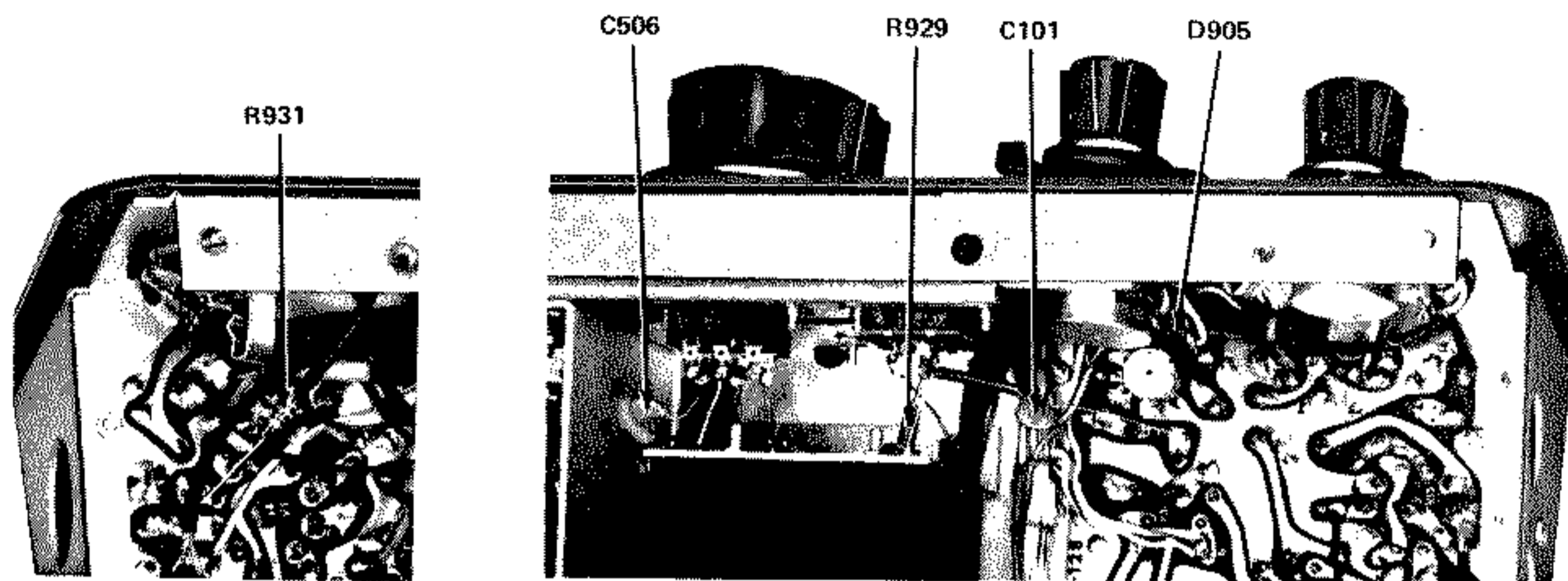

Figure 2-28

CHASSIS PHOTOGRAPHS



TOP VIEW



BOTTOM VIEW

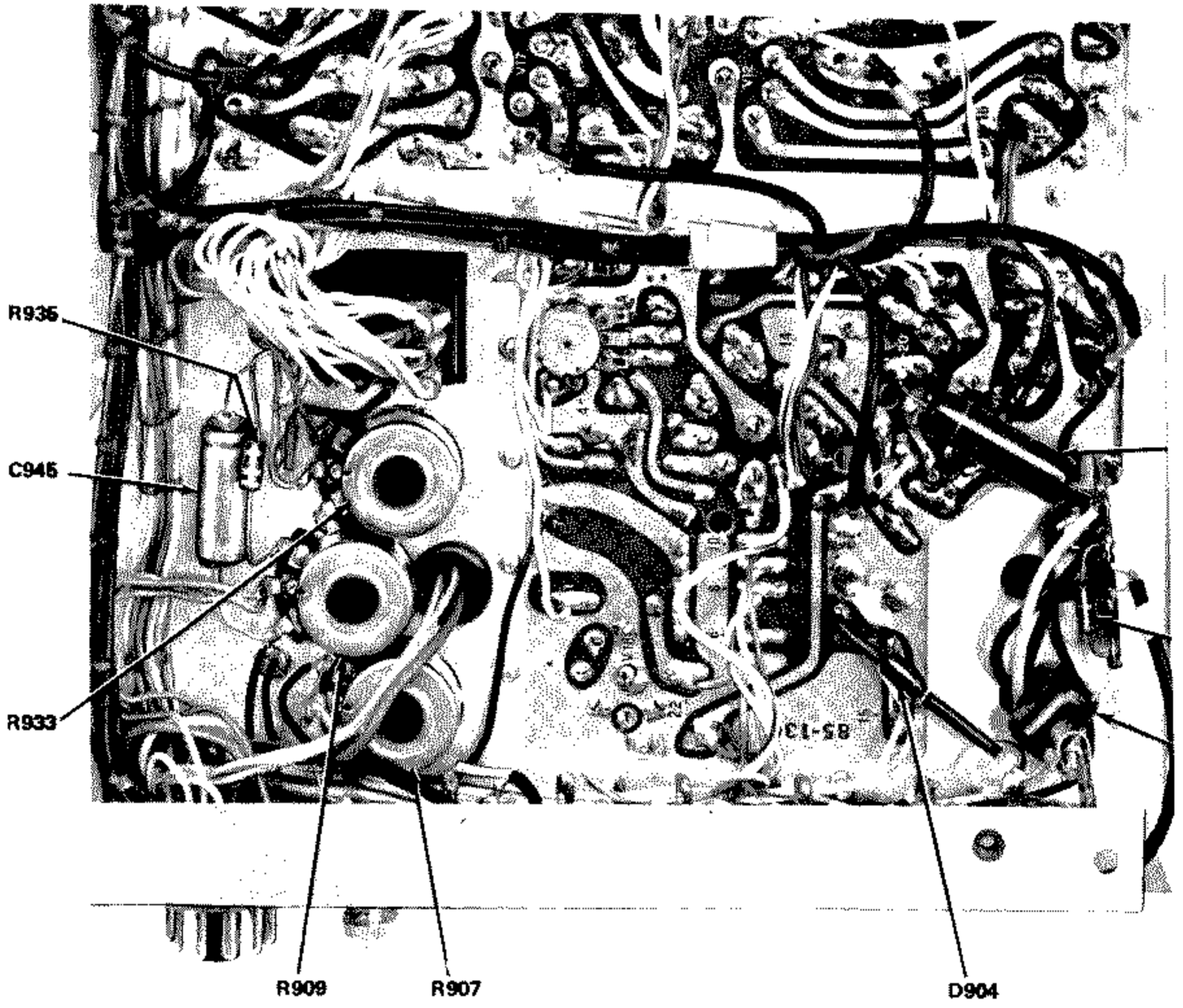

CIRCUIT BOARD X-RAY VIEWS (VIEWED FROM FOIL SIDE)

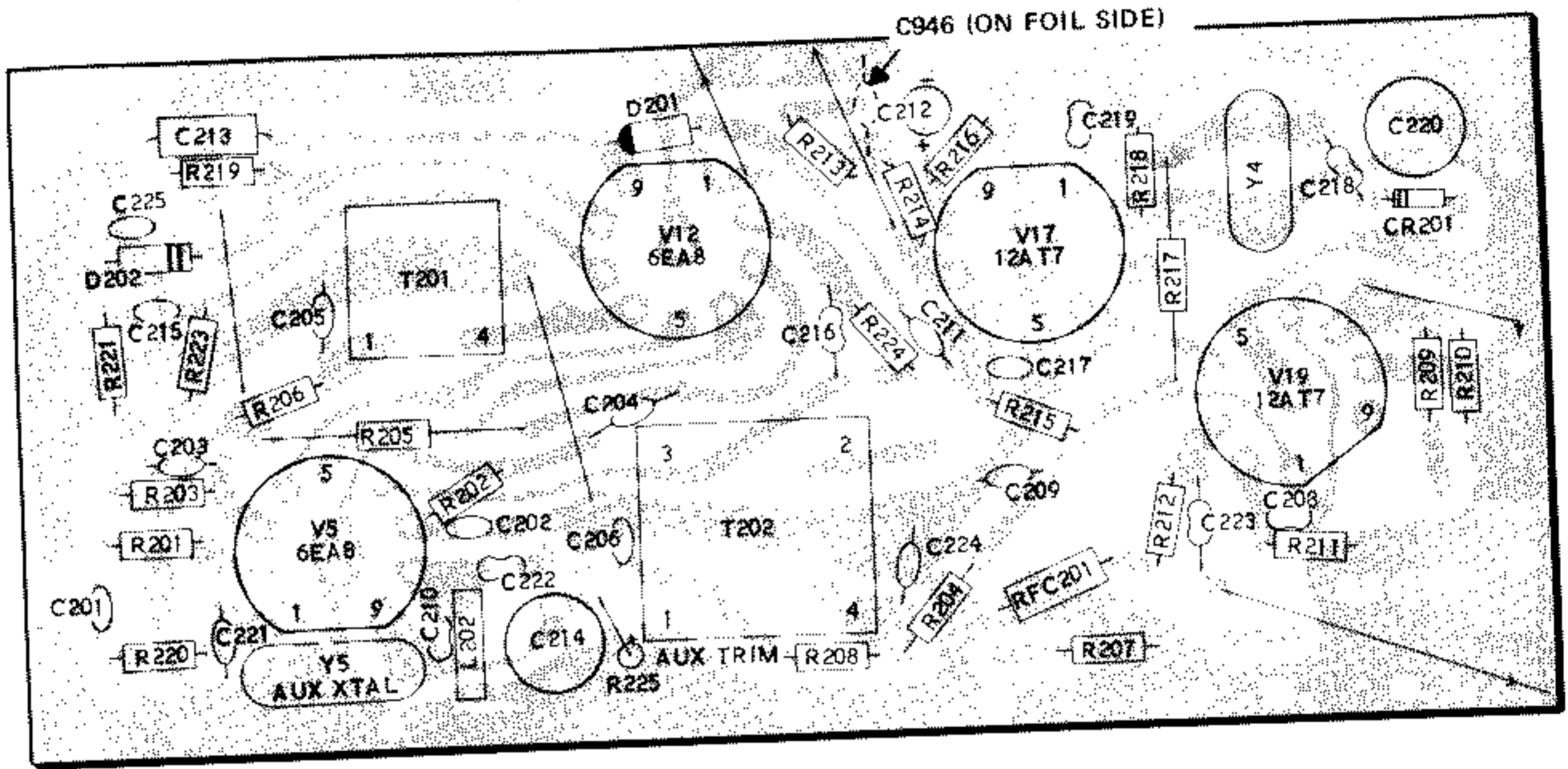

BANDPASS CIRCUIT BOARD
#85-129-4

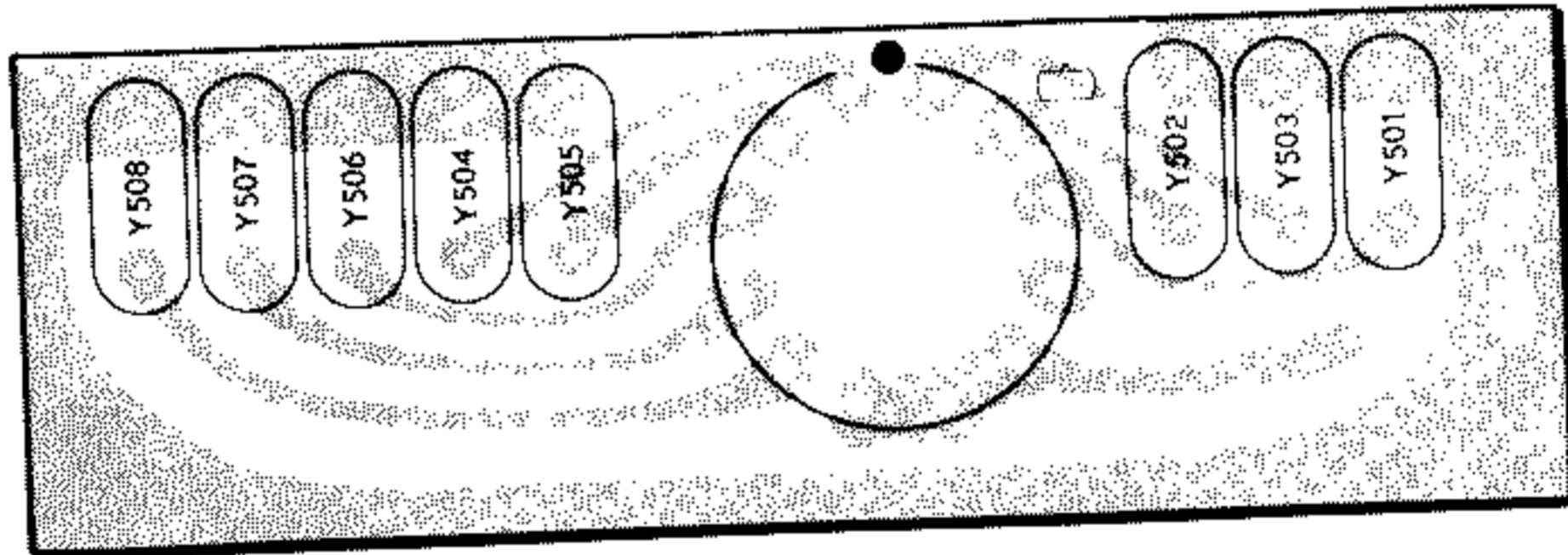

CRYSTAL CIRCUIT BOARD
#85-132-1

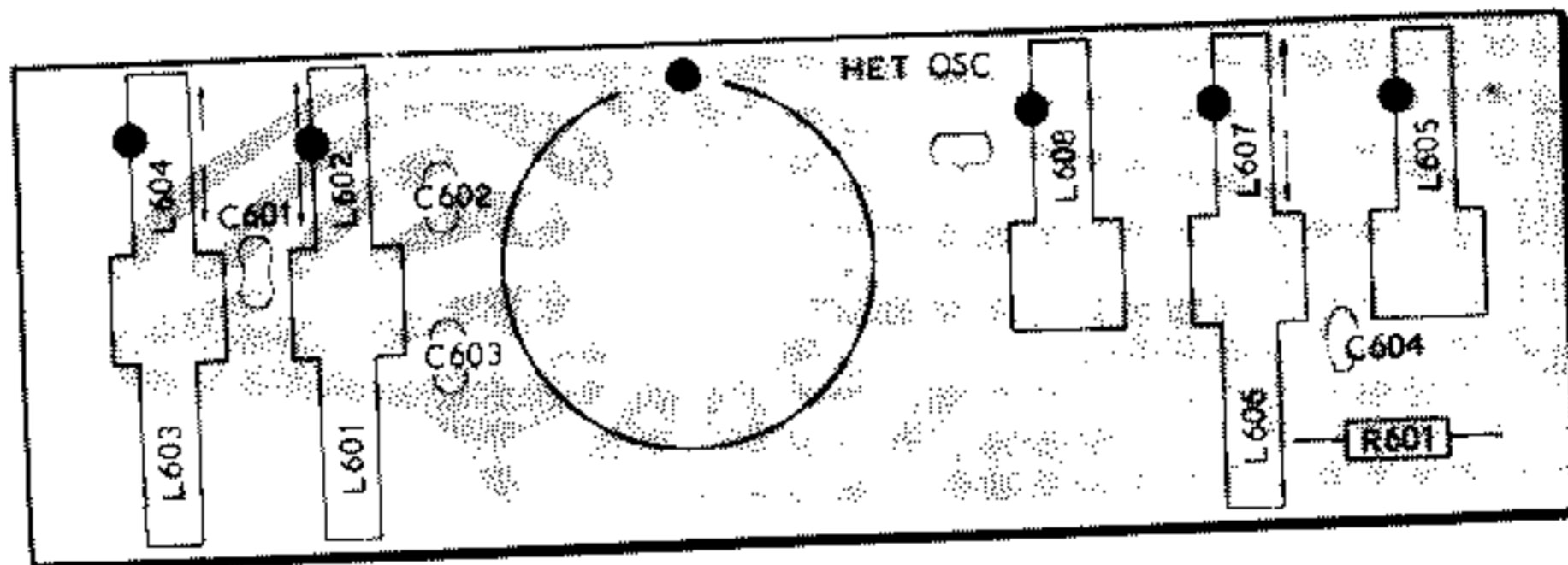

HETERODYNE OSCILLATOR CIRCUIT BOARD
#85-133-1

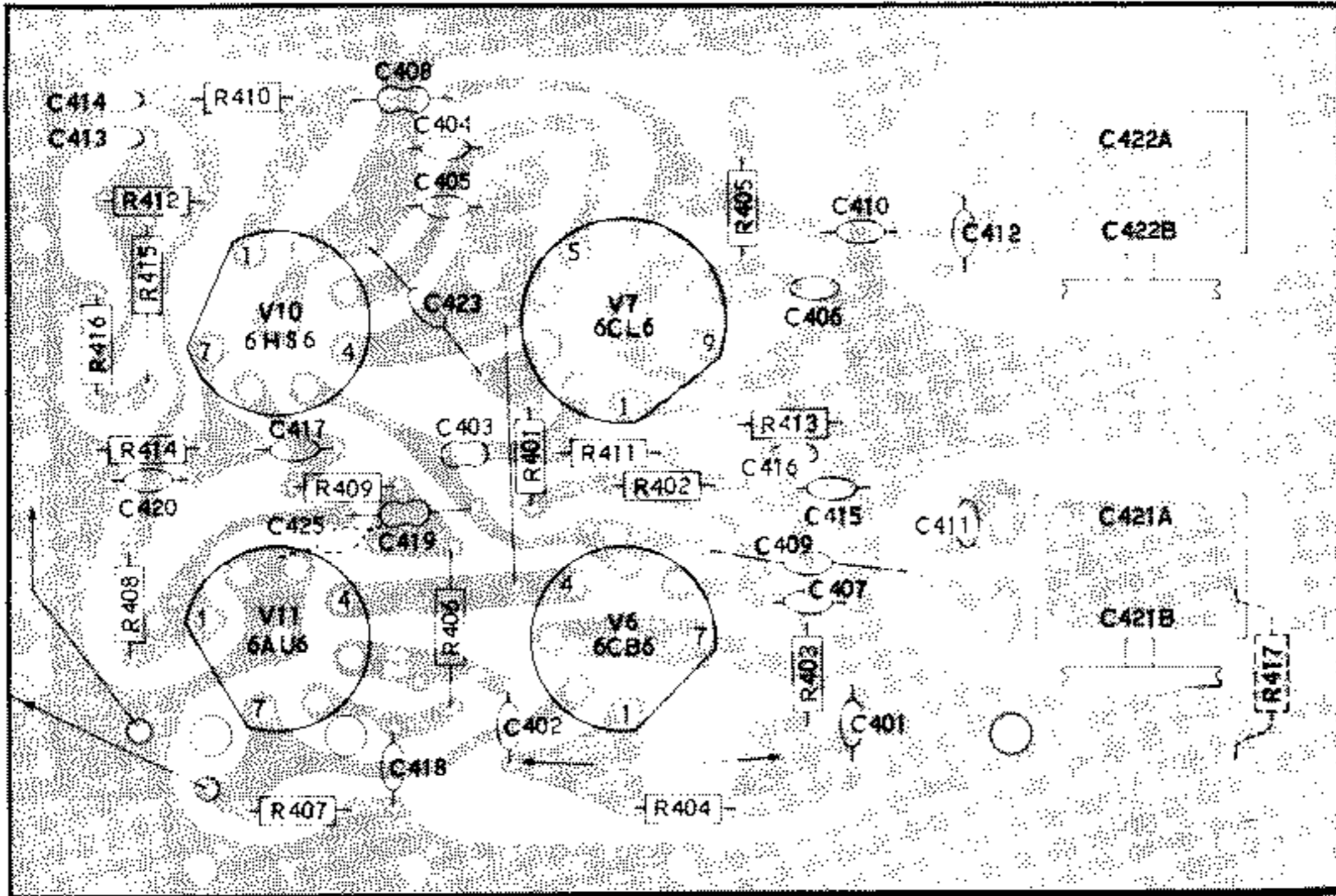

RF-DRIVER CIRCUIT BOARD
#85-131-5

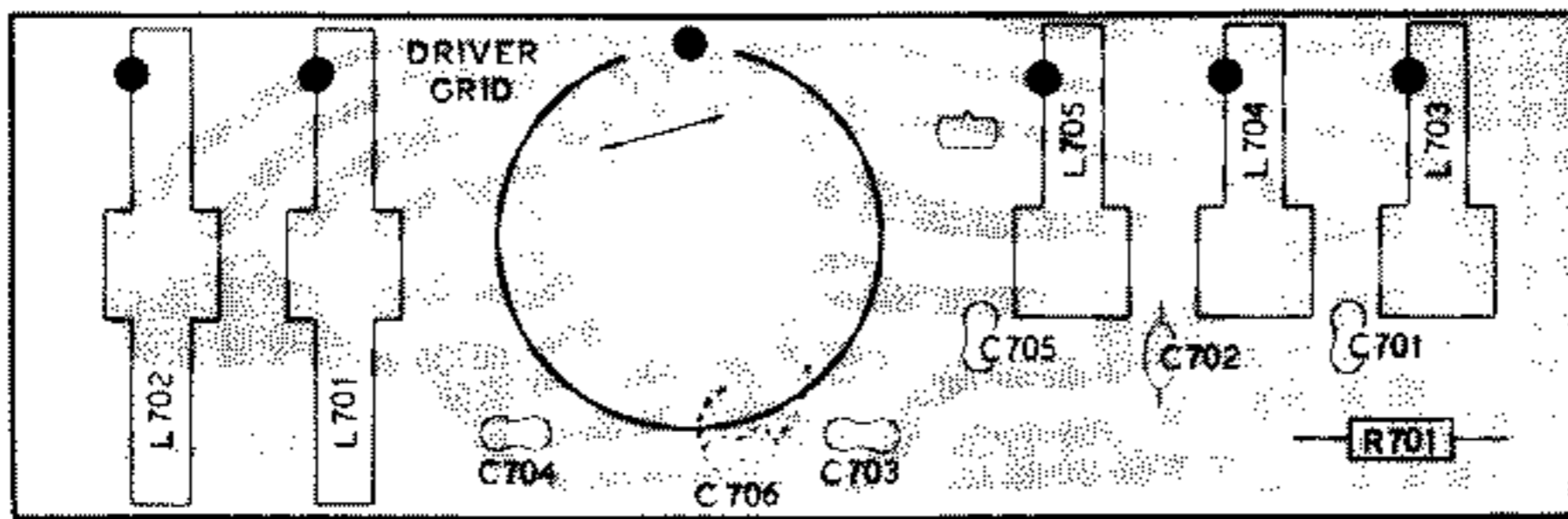

DRIVER GRID CIRCUIT BOARD
#85-133-2

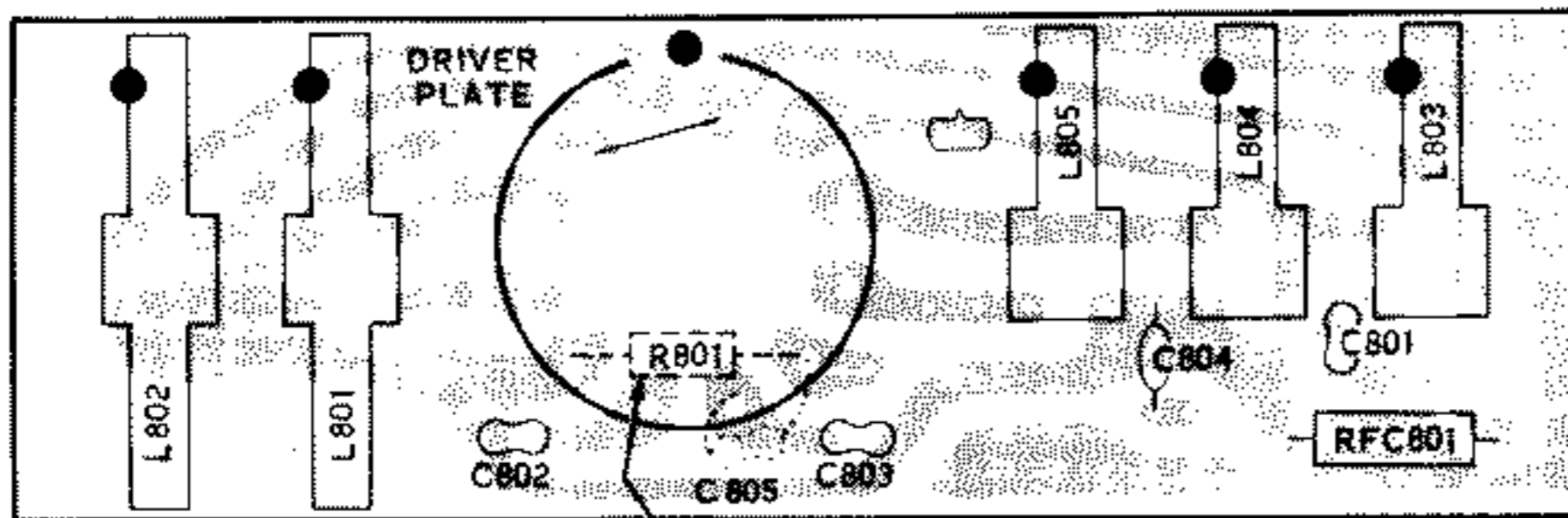

THIS RESISTOR LOCATED
ON SWITCH WAFER.

DRIVER PLATE CIRCUIT BOARD
#85-133-3

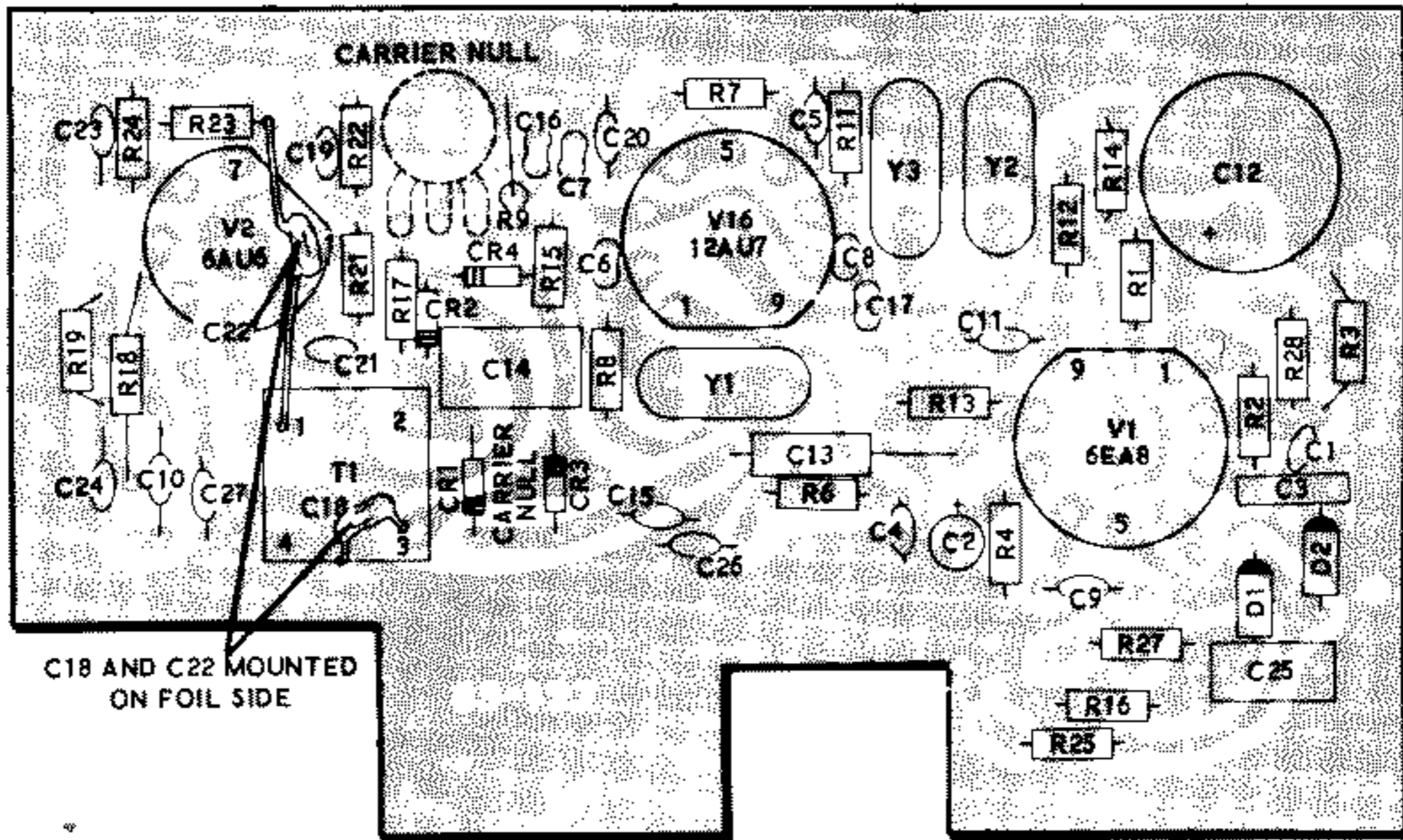

MODULATOR CIRCUIT BOARD
#85-127-3

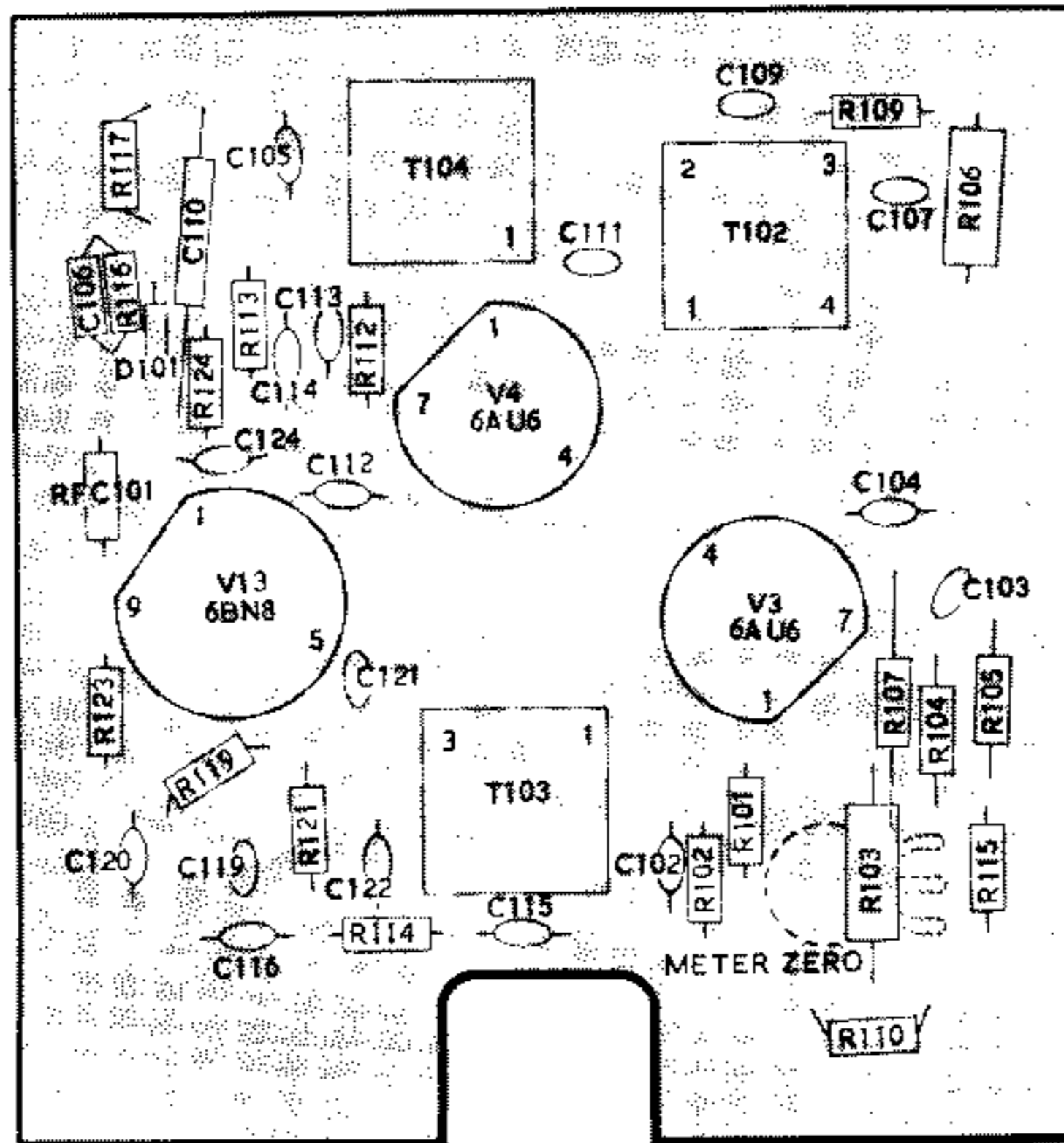

IF CIRCUIT BOARD
#85-128-2

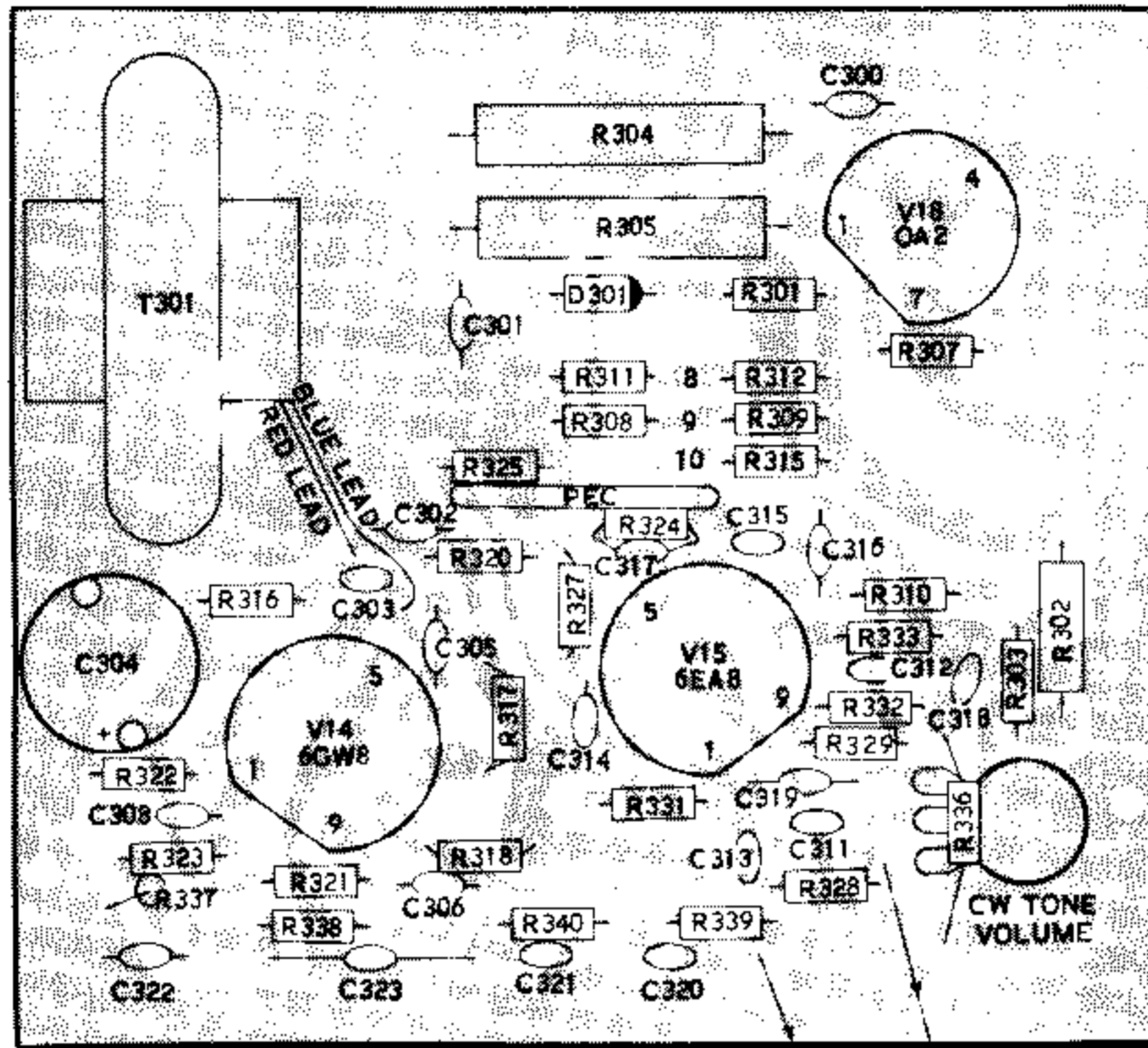

AUDIO CIRCUIT BOARD
#85-130-3

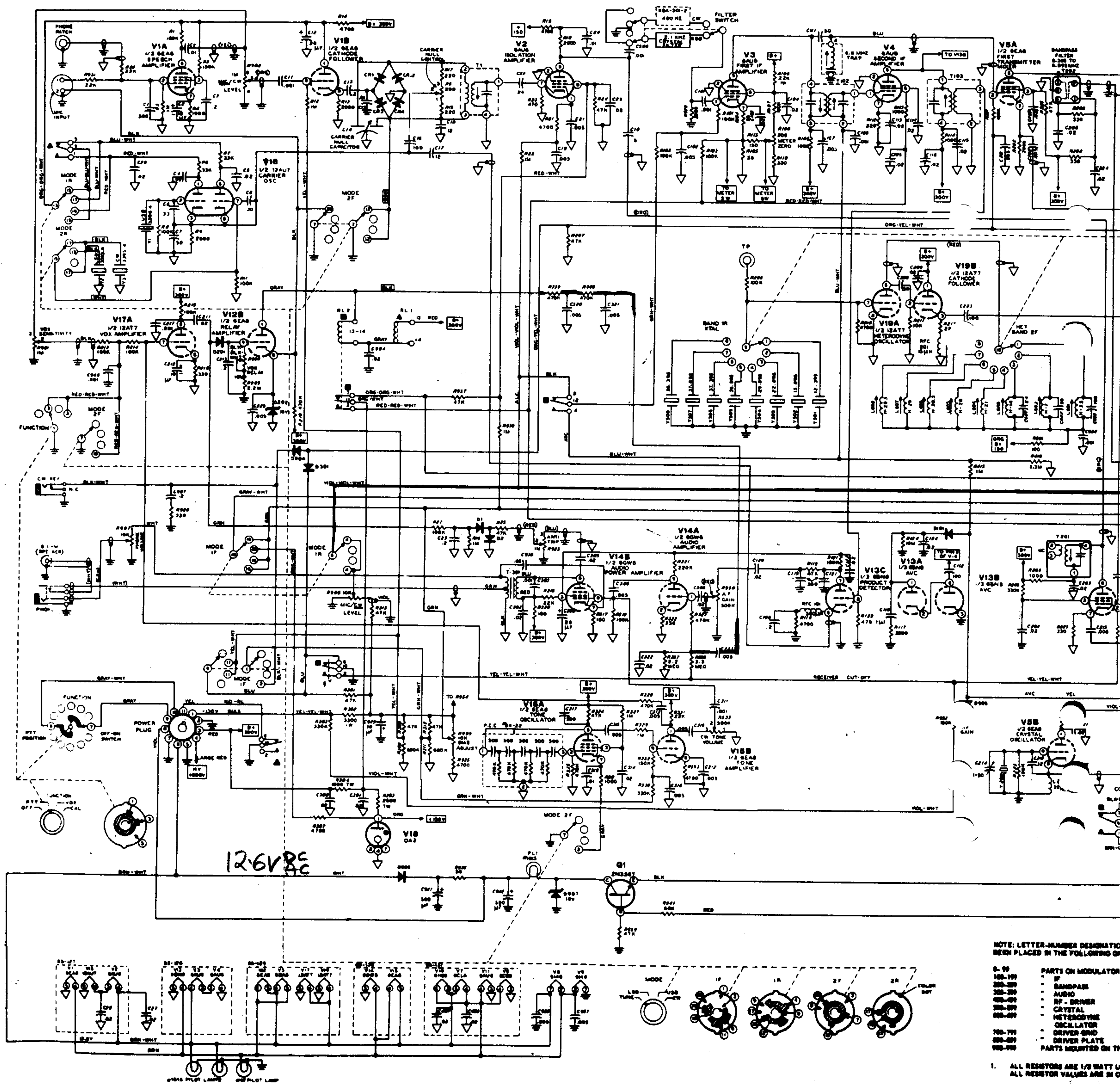

NOTE: LETTER-NUMBER DESIGNATION HAS BEEN PLACED IN THE FOLLOWING COLUMNS:

80-99	PARTS ON MODULATOR
100-199	IF
200-299	BANDPASS
300-399	AUDIO
400-499	RF - DRIVER
500-599	CRYSTAL
600-699	METER/TYPE
700-799	OSCILLATOR
800-899	DRIVER/GRID
900-999	PARTS MOUNTED ON THE

1. ALL RESISTORS ARE 1/2 WATT UNLESS OTHERWISE SPECIFIED. ALL RESISTOR VALUES ARE IN OHMS UNLESS OTHERWISE SPECIFIED.
2. ALL CAPACITOR VALUES OVER 1000 P.F. ARE IN MICROFARADS UNLESS OTHERWISE SPECIFIED.
3. REFER TO THE X-RAY AND CHECK OF PARTS.

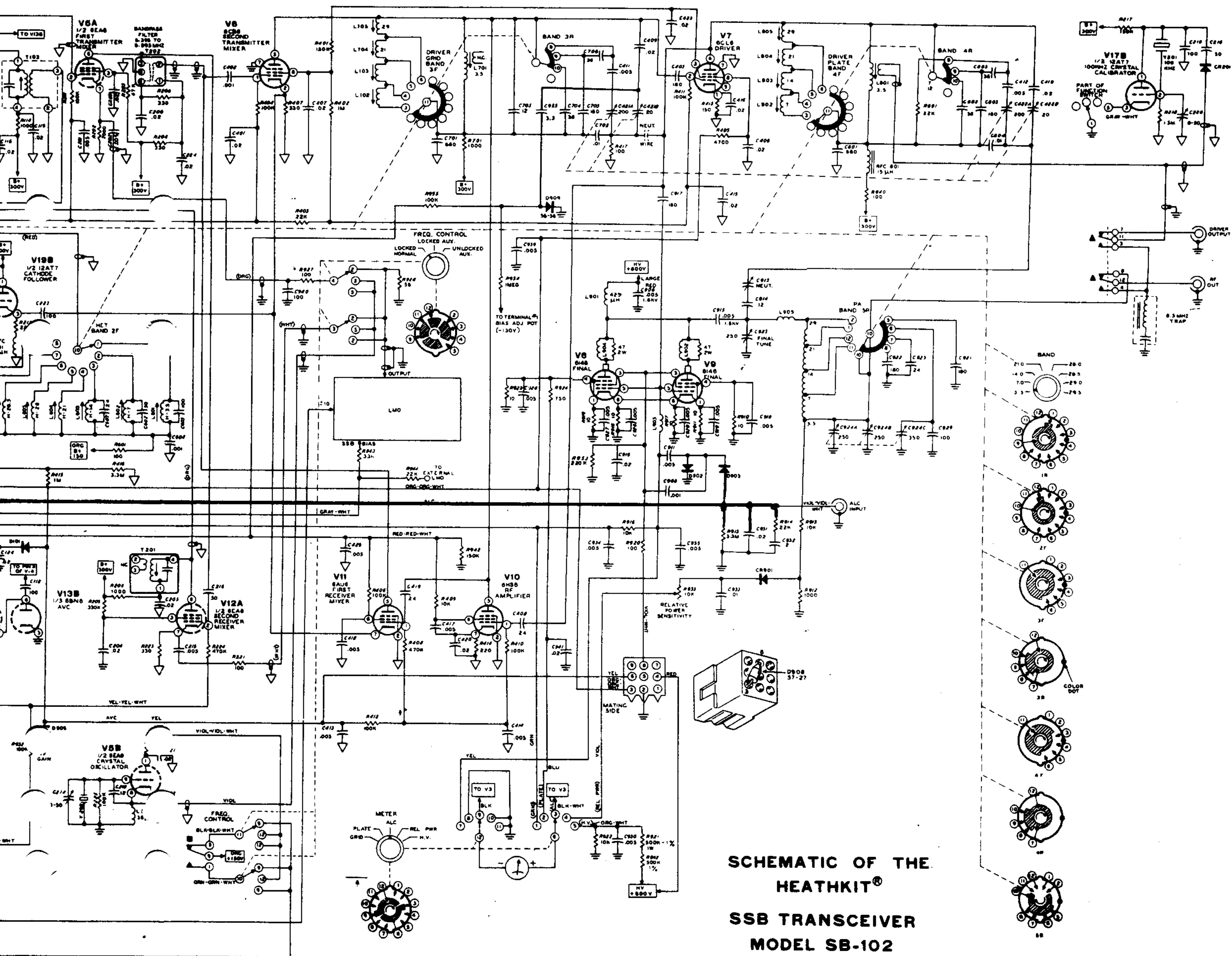

**SCHEMATIC OF THE
HEATHKIT®
SSB TRANSCEIVER
MODEL SB-102**

NOTE: LETTER-NUMBER DESIGNATIONS FOR RESISTORS, CAPACITORS, ETC., HAVE BEEN PLACED IN THE FOLLOWING GROUPS:

RESISTOR VALUE	PARTS ON MODULATOR CIRCUIT BOARD.
0-99	IF
100-199	BANDPASS
200-299	AUDIO
300-399	RF - DRIVER
400-499	CRYSTAL
500-599	METERDRIVE
600-699	OSCILLATOR
700-799	DRIVER GRID
800-899	DRIVER PLATE
900-999	PARTS MOUNTED ON THE CHASSIS.

- ALL RESISTORS ARE 1/2 WATT UNLESS MARKED OTHERWISE. ALL RESISTOR VALUES ARE IN OHMS (K = 1,000, MEG = 1,000,000).
- ALL CAPACITOR VALUES OVER 1 ARE IN μ F UNLESS MARKED OTHERWISE.
- REFER TO THE X-RAY AND CHASSIS VIEWS FOR PHYSICAL LOCATION OF PARTS.

- SEE THE VOLTAGE CHARTS (FOLD-OUT FROM PAGE 122) AND THE RESISTANCE CHART (FOLD-OUT FROM PAGE 123) FOR ALL MEASUREMENTS.

- ALL SWITCHES ARE IN THE POSITION INDICATED BY THE KNOB POINTERS.

- ARROW (↻) INDICATES CLOCKWISE ROTATION OF KNOB (VIEWED FROM KNOB END).

- INDICATES HOOKUP WIRE NOT IN THE HARNESS.

- () INDICATES COLOR CODE OF COAXIAL CABLE.

- ALL RELAY CONTACTS SHOWN IN TRANSMIT/TUNE POSITION.

- FOR GREATER CLARITY, RELAY SECTIONS ARE SHOWN CLOSEST TO THE CIRCUITS IN WHICH THEY ARE USED. ONE OF THE FOLLOWING MARKS IS USED TO IDENTIFY THE SEPARATED SECTION OF THE RELAYS:

- ▲ = PART OF RELAY RL1
- = PART OF RELAY RL2

- SWITCH WAFERS ARE IDENTIFIED AS IN THE FOLLOWING EXAMPLE:

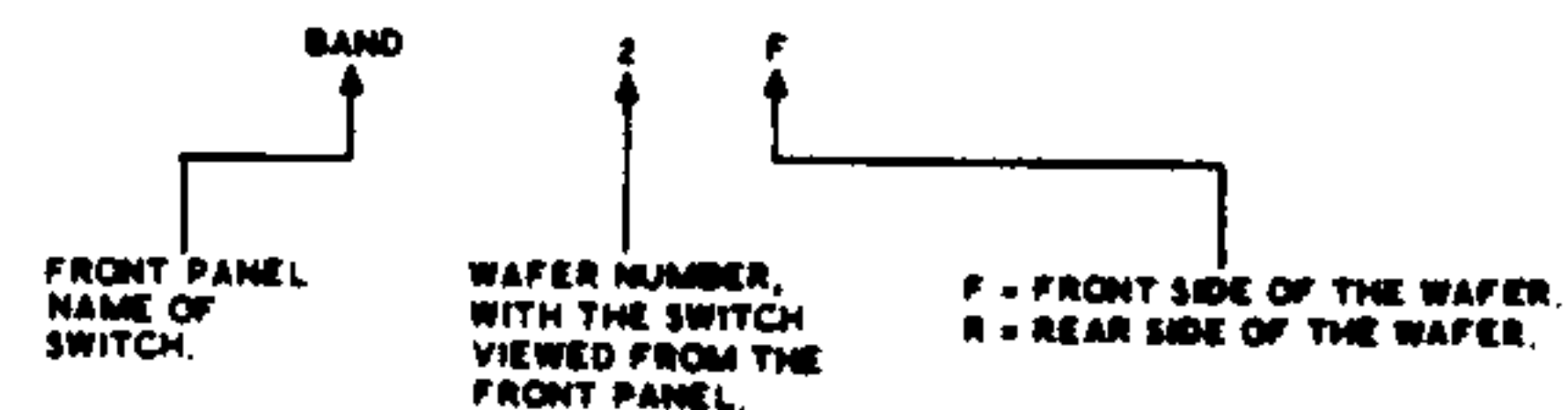

- ≡ INDICATES CHASSIS GROUND

- ▽ INDICATES CIRCUIT BOARD GROUND.

K4XL's **BAMA**

This manual is provided **FREE OF CHARGE** from the "BoatAnchor Manual Archive" as a service to the Boatanchor community.

It was uploaded by someone who wanted to help you repair and maintain your equipment.

If you paid anyone other than BAMA for this manual, you paid someone who is making a profit from the free labor of others without asking their permission.

You may pass on copies of this manual to anyone who needs it. But do it without charge.

Thousands of files are available without charge from BAMA. Visit us at <http://bama.sbc.edu>